

# SJE VERTICALMASTER® II Pump Switch

Mechanically-activated, pump switch designed to operate in sump applications with limited space.

This mechanically-activated pump switch is designed to operate in non-potable water with limited space. It works well in small sump chambers and laundry trays, as well as in large tanks. This switch is not recommended for a sewage environment.

The SJE VerticalMaster® II pump switch is not sensitive to turbulence.

It is available for pump down application only.



## FEATURES

- Adjustable pumping range of 2 to 17 cm (.75 to 6.5 inches).
- Includes standard boxed packaging.
- UL Recognized for use in non-potable water.
- CSA Certified.
- Three-year limited warranty.

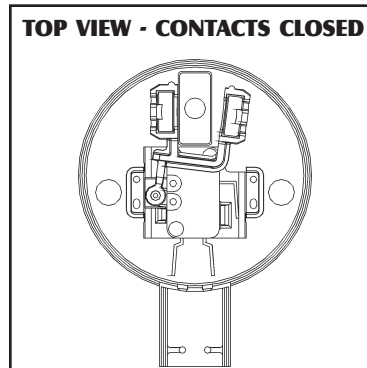
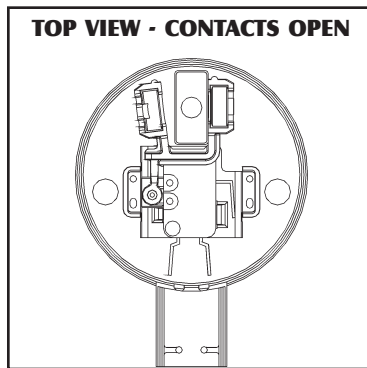

## OPTIONS

This switch is available:

- CE Compliant units available upon request.
- in standard cable lengths of 3, 5, 6, and 10 meters (10, 15, 20, or 30 feet)

## SPECIFICATIONS

**CABLE:** flexible 18 gauge, 2 conductor (UL, CSA) SJOW

**MOUNTING BRACKET & HOSE CLAMP:** stainless steel

**LIFT ROD:** injection molded acetal plastic

**FLOAT STOP:** neoprene

**SWITCH AND FLOAT HOUSING:** high impact, corrosion resistant, PVC housing for use in non-potable water up to 52°C (125°F)

**Overall dimensions:** 30.5 cm high x 12.7 cm x 7.6 cm wide (12 inch high x 5 inch x 3 inch wide)

**Switch housing dimensions (excluding cable entrance):** 5 cm high x 7.1 cm diameter (2 inch high x 2.8 inch diameter)

**Float housing dimensions:** 6.4 cm high x 6.9 cm diameter (2.5 inch high x 2.7 inch diameter)

### ELECTRICAL:

**125/250 VAC 50/60Hz Single Phase:**

**Maximum Pump Running Current:**  
10 amps

**Maximum Pump Starting Current:**  
60 amps

**NOTE:** This switch must be used with pumps that provide integral thermal overload protection. This switch is **NOT** recommended for non-arcing electrical loads.



Ross Brown Sales Pty Ltd

ABN 28 000 690 362  
Phone: 612 9899 2744 Fax: 612 9899 4233  
Email: [sales@rossbrownsales.com.au](mailto:sales@rossbrownsales.com.au)  
Web: [www.rossbrownsales.com.au](http://www.rossbrownsales.com.au)

**SJE**  
**Rhombus**  
CONTROLS

PO Box 1708, Detroit Lakes, MN 56502  
1-218-847-1317

email: [sje@sjerhombus.com](mailto:sje@sjerhombus.com)

[www.sjerhombus.com](http://www.sjerhombus.com)