

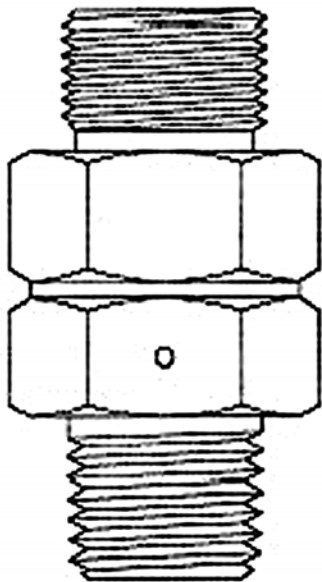

Unloading Check Valves

Load Genie®



**"CA" Series
Load Genie®
for Tube Compression Fitting**

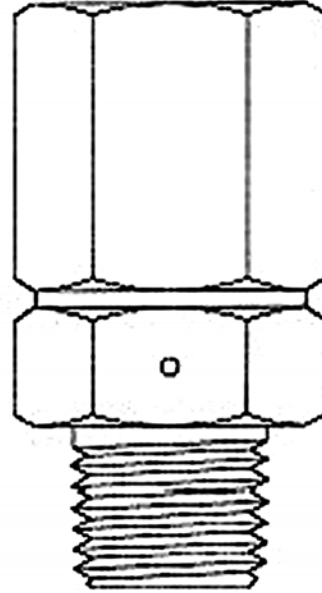

**"PA" Series
Load Genie®
for Pipe**

A compressor running in a "start-stop" mode operates more efficiently if the pressure trapped in the compressor head and discharge line is released after each pump-up cycle. This allows smoother starts and the use of a motor with lower starting torque.

The most convenient way to release this trapped pressure is to use a Load Genie® combination check and unloader valve, available only from Control Devices, Inc. Simply install this unique valve in the compressor discharge line, and the Load Genie® does the rest!

The Load Genie® senses air flow when the compressor is running and closes an unloading orifice port. When airflow stops (such as when the pressure switch turns off the motor), the Load Genie® opens the unloading orifice to release head pressure, and the built-in check valve keeps receiver air from leaking back into the discharge line and compressor head.

Alternative methods rely on external unloading valves mounted on the pressure switch or compressor. These external unloading valves are connected with appropriate tubing and fittings to the compressor discharge line or compressor head. A tank check valve is also required. These systems, then consist of the unloading valve, connecting tubing with appropriate fittings, a tank check valve, and the labour to install it all.

Compare this to the single component installation of a Load Genie® and the advantages are apparent.

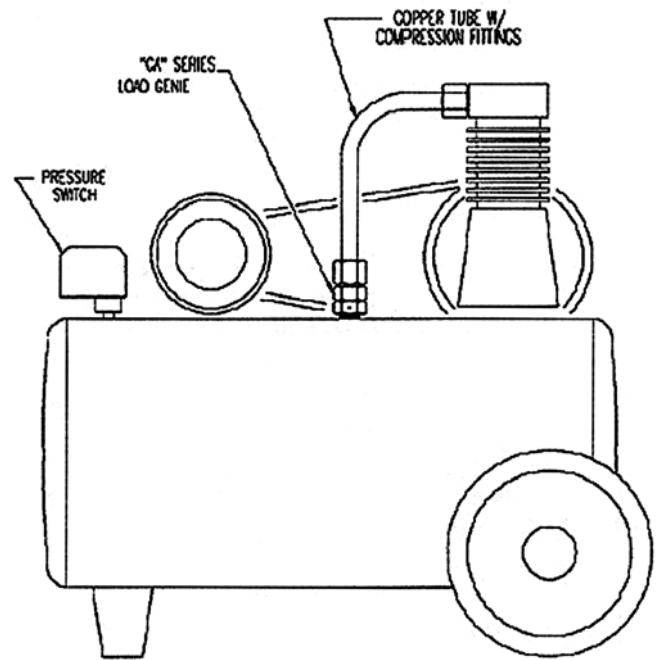

TYPICAL LOAD GENIE® INSTALLATION



Unloading Check Valves

Load Genie®

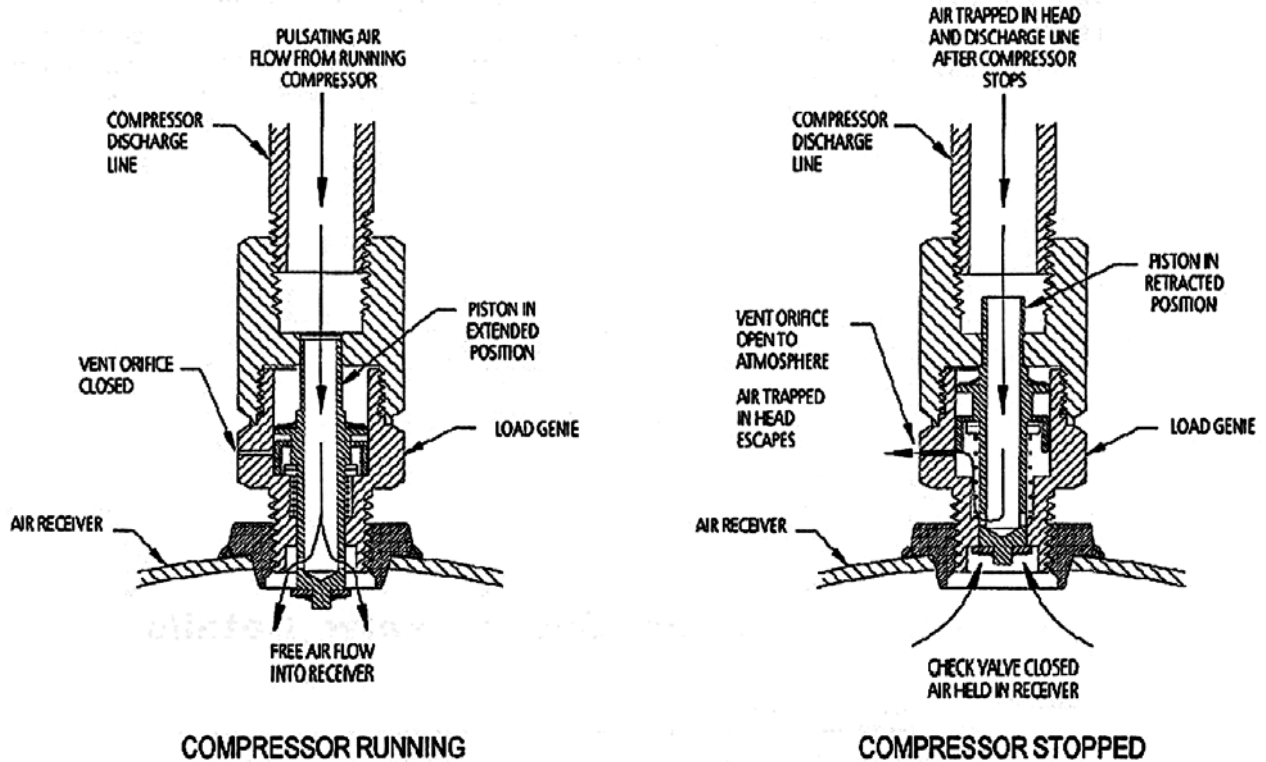

Model	Inlet	Outlet	Min & Max Flow SCFM	Dimensions (mm)		Weight (gms)	Part Number
				Length	Hex		
CA-6	3/8" O.D. tube compression	1/4" MPT	1-6	39.7	19.0	57	400000
PA-6	1/4" FPT	1/4" MPT	1-6	44.4	19.0	71	4000100
CA-12	1/2" O.D. tube compression	3/8" MPT	3-12	42.9	20.6	71	4000200
PA-12	3/8" FPT	3/8" MPT	3-12	46.0	20.6	85	4000300
CA-24	3/4" O.D. tube compression	1/2" MPT	8-24	54.0	25.4	142	4000400
PA-24	1/2" FPT	1/2" MPT	8-24	57.1	25.4	170	4000500
CA-48	3/4" O.D. tube compression	3/4" MPT	15-48	55.6	30.2	170	4000600
PA-48	3/4" FPT	3/4" MPT	15-48	60.3	30.2	227	4000700

ORDER GUIDE

1. It is **most important** to match the rated flow range of the Load Genie® with the compressor flow capacity. Also keep in mind that as the compressor discharge goes up, the flow goes down. If the flow capacity of the compressor drops below the minimum rated flow of the Load Genie®, the valve will react as if the compressor had stopped, and will vent the discharge line. Therefore, it is better to size the Load Genie® towards the maximum end of its rated flow range.
2. Next, select the desired inlet configuration, tubing compression fitting or internal pipe thread. Please note that, based on the flow selection criteria above, the inlet and outlet sizes may not match the fitting sizes found in the compressor and tank. In this case, use appropriate reducers available in any hardware store.
3. Order by part number