

# MODEL™ 1700

## INSTALLATION GUIDE

### Model 1700™

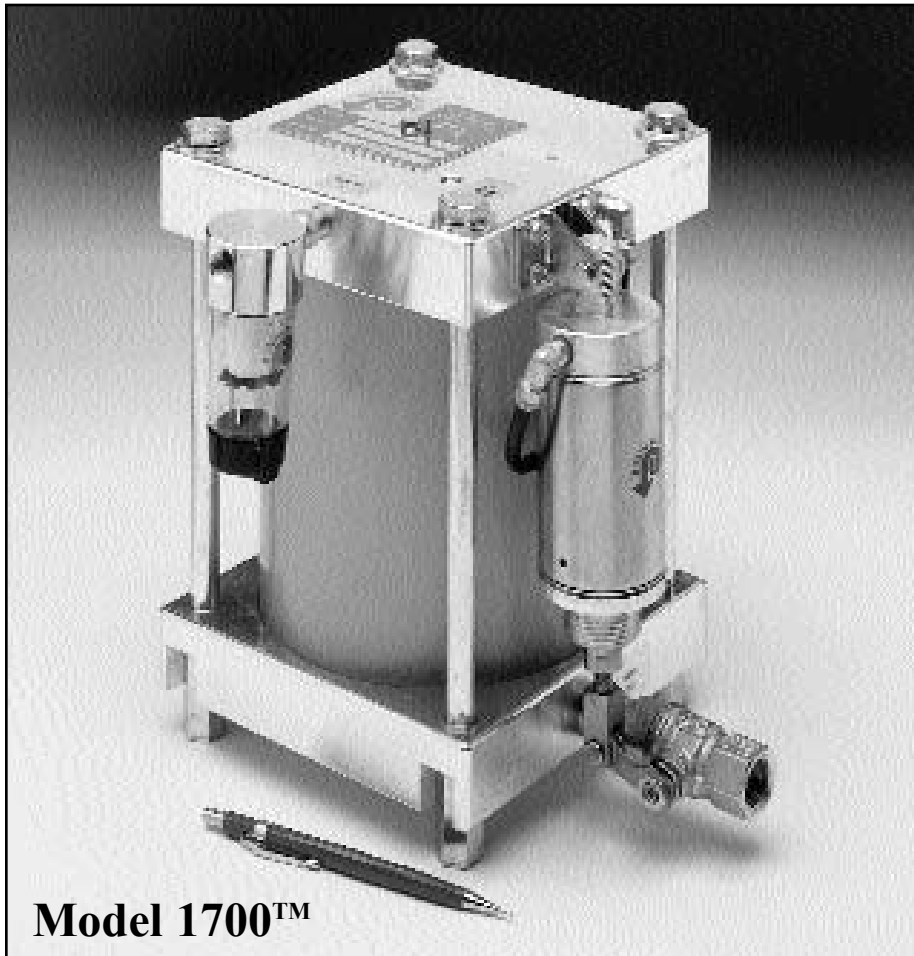

**Model 1700™**

The patented Model 1700™ was designed for removing condensate from compressed air systems. Since it is totally pneumatic, it does not require any electricity and can be easily installed using simple piping connections at any point in a system including remote locations. It can handle pressures up to 170 PSIG and liquid temperatures up to 170°F. It has 1/2" NPT inlet and outlet ports and a full 1/2" smoothly contoured condensate flow path. The industrially robust, highly reliable Model 1700™ has few moving parts and at 21 pounds, can stand up to the most demanding applications with minimal maintenance.

In addition to the Model 1700™, Drain-All has a full range of products based on a modular design with the ability to change components, materials of construction and finishes to provide application specific solutions for any application.

### INDEX

Installation.....	2	Install Locations.....	12
Start-up & Troubleshooting.....	3		
Dimensional Print.....	4		
Product Technology, How It Works.....	5		
Component Parts Drawing.....	6		
Parts & Materials of Construction.....	7		
Frequently Asked Questions.....	8		
Drain-All Solves Problems.....	9		
Team Drain-All.....	10		
Warranty.....	11	Warranty Card .....	11

### SPECIFICATIONS

	Model 1700™
	<b>#870100</b>
Max Liquid Temp - °F (°C)	170 (76.7)
Max Liquid Pressure - PSIG (BARG)	170 (11.7)
Control Air Min - PSIG (BARG)	40 (2.8)
Control Air Max - PSIG (BARG)	130 (9.0)
Ht - inches (cm)	11 (27.9)
Width - inches (cm)	9-1/4 (23.5)
Depth (Inlet/BV) - inches (cm)	10-1/2 (26.7)
Inlet/Outlet - NPT	1/2
Control Air - NPT	1/4
Balance Line - NPT	1/8
Capacity	Varies with pressures/piping
Weight - LBS (KG)	21 (9.5)

Drain-All, Inc.



**Ross Brown Sales Pty Ltd**

ABN 28 000 690 362  
Phone: 612 9899 2744 Fax: 612 9899 4233  
Email: [sales@rossbrownsales.com.au](mailto:sales@rossbrownsales.com.au)  
Web: [www.rossbrownsales.com.au](http://www.rossbrownsales.com.au)

**The Drain-All, Inc. Quality System  
ISO 9001:2000 Certified**

United States Patents: 4,444,217 4,562,855 4,574,829 5,004,004 5,014,735 5,983,919



# INSTALLATION

Before installing the Drain-All, a review of the following items will help make the right decision regarding options which could be used to ensure long-term maintenance free operation.

## RUST AND SCALE

Even though the Drain-All is designed for handling rust and scale, it is recommended that the system be blown down after all piping is installed and before the Drain-All is connected to the piping. The Drain-All, with a large, smooth, liquid flow path, easily handles contaminants in the liquid once the system is in operation. If there is excessive rust and scale on a continuous basis, consider using the Rust Handler™ designed for compressed air systems that have extremely heavy amounts of rust and scale.

## CONTROL AIR & BALANCE LINE

The control air line provides air through the sealed center tube to operate the air cylinder. Clean dry air should be used for this control air supply. The balance line provides a means to handle the displaced air as the liquid enters the reservoir. The control air line and the balance line are two separate lines which have nothing in common with each other and should never be connected to each other in any way. Do not tie them together with a tee fitting.

## CONTROL AIR

Control air pressure requirements vary by product and must be regulated within specifications provided in the product's Installation Guide. If the specified pressure for control air cannot be supplied in your application, contact Drain-All Technical Service for information on control air options to accommodate your available control air pressure.

## BALANCE LINE

The balance line must have either (1) exactly the same pressure as the vessel being drained or (2) slightly less pressure than the vessel being drained.

The same pressure is achieved when the balance line is tied back into the vessel being drained, such as connecting the balance line at a tee fitting on the vessel's pressure gage or access port. A slightly lower pressure may be achieved by locating the balance line connection on the air header pipe a few feet downstream from the vessel being drained. When hooking the balance line to an air header, connect it to the header prior to any other vessel attached to the header.

If there is absolutely no place to connect the balance line into the air system, or if a temporary installation is to be made while waiting for the next shutdown to tie in the balance line, the balance line can be vented to atmosphere. Install a shut-off/isolation valve into the port on top of the Drain-All where "Balance Line" is indicated. Then follow the start-up instructions for adjusting the opening of the balance line shutoff/isolation valve. There will be very little air loss to atmosphere.

## NO MANIFOLDS

There cannot be multiple system drains through a manifold to one Drain-All. This will not work because all system drains will not be of the same pressure. Therefore, the liquid from the higher pressure drain lines will bypass the Drain-All and flow backwards up the lower pressure drains. Installing check valves on system drains is not a solution because pressure variations which inhibit proper operation will still be present. Proper installation of the balance line is not possible with multiple drains hooked up through a manifold.

## CORROSION

There are Drain-All, Inc. products available which include corrosion resistant coatings and materials. If the application environment is highly corrosive, check these products and options to determine if they should be specified. Also available are Drain-All, Inc. products which handle higher pressures and temperatures.

## INSTALLATION STEPS

1. Prior to installing the Drain-All, blow down the vessel being drained to remove excessive rust, scale, and dirt knocked loose during piping installation.
2. Remove the Drain-All from the box and set it in an upright position where it will be connected. Most Drain-All, Inc. products do not have to be secured. Larger volume and higher pressure products may require some form of movement restraint. To ensure proper operation in all installation layouts, the top of the Drain-All should be lower than the bottom of the vessel being drained.
3. Using 1/2" pipe, connect the vessel being drained to the 1/2" liquid inlet on the base of the Drain-All. Be sure to install a shut-off valve and a bypass valve between the vessel being drained and the Drain-All. This will allow easy removal of the Drain-All "on the run" during any preventive maintenance activities. After installing the piping, close the inlet shut-off valve.
4. Using 1/2" pipe, connect the Drain-All discharge ball valve to a sealed drain pipeline or enclosed/covered trough. The discharged liquid is under pressure and can splash back if directed downward toward the bottom of a simple, shallow, open trough-type floor drain.
5. Connect the balance line from the Drain-All to the appropriate connecting point on the vessel being drained using appropriate size and pressure rated tubing or pipe. Install a shutoff/isolation valve in this line. After installing the balance line, close the balance line shutoff/isolation valve.
6. Using appropriate size and pressure rated tubing or pipe, connect the control air supply to the control air filter assembly inlet on the Drain-All. Install a shut-off/isolation valve in this line. Always use the cleanest and driest air possible to ensure long term maintenance free operation. After connecting the control air supply, close the control air shutoff/isolation valve.



# START-UP & TROUBLESHOOTING

## START-UP

1. Close both the control air and balance line shutoff/isolation valves.
2. Bring up system pressure.
3. Fully open control air shutoff/isolation valve. Check for leaks in control air line. Push the “Push to Test” button on top of the Drain-All to verify the air cylinder strokes, opening the discharge ball valve. Leave control air needle valve open.

**4a. Applications where the balance line is connected back to vessel being drained.** Fully open the balance line shutoff/isolation valve and leave it fully opened. Check for air leaks on the line and fittings.

**4b. Applications where the balance line is vented to atmosphere or connected to a header pipe leaving the vessel being drained.** Open the balance line shutoff/isolation valve only enough to ensure a small amount of air flows through it. This will be adjusted in a later step.

5. Gradually open the water inlet shutoff/isolation valve to the full open position to allow liquid to enter the Drain-All. The reservoir will fill until the float pops up to the upper position actuating the control circuit extending the air cylinder and opening the discharge ball valve. Once the discharge starts, the liquid level in the Drain-All reservoir begins to lower. This lowers the float back to its original position which returns the air cylinder to the home position closing the ball valve.

**6a. Applications where the balance line is connected back to vessel being drained.** When the balance line is connected back to the vessel being drained, there is no pressure differential between the water inlet and balance line and there will be no bubbles in the liquid as water enters the reservoir. In this application keep the balance line shutoff/isolation valve fully open at all times. The top of the Drain-All must be below the bottom of the vessel being drained.

**6b. Applications where the balance line is vented to atmosphere or connected to a header pipe leaving the vessel being drained.** With liquid in the reservoir and the liquid discharge ball valve in the closed position, close the balance line shutoff/isolation valve. As you slightly open the this valve, look into the translucent sleeve just above the water inlet port and look for a trickle of small bubbles going upward. Continue to open the valve until you see these bubbles indicating a proper open setting for this valve. Bubbles will only be seen if there is a pressure differential that occurs when the balance line is vented to atmosphere or to a header leaving the vessel being drained.

7. Once properly installed, no further adjustments to the Drain-All are necessary. The Drain-All is fully automatic, discharging on demand as needed when liquid accumulates.

## TROUBLESHOOTING

### 1. Water does not enter.

**A.** Balance line shutoff/isolation valve is closed which does not allow liquid to enter the Drain-All.

**Solution:** Adjust balance line shutoff/isolation valve per instructions.

**B.** Liquid inlet shut-off valve is closed.

**Solution:** Fully open water inlet shutoff/isolation valve.

**C.** Pipe from vessel drain port to Drain-All inlet is plugged.

**Solution:** Clear obstruction.

**D.** Location of balance line connection causes higher balance line pressure than water inlet pressure. Drain-All is “back flowing”.

**Solution:** Refer to installation instructions for proper balance line installation.

### 2. Fills and will not drain.

**A.** Control air line shutoff/isolation valve is closed, or not fully open.

**Solution:** Fully open control air shutoff/isolation valve.

**B.** Lack of adequate air pressure on con-

trol air line.

**Solution:** Provide more than the minimum required PSIG to control air line connection per the product specification. If there is not enough control air pressure available, there are lower control air pressure options available - contact Drain-All for details.

**C.** Hole in valve stem clogged.

**Solution:** Clear obstruction. Do not alter this precision hole diameter.

**D.** Filter element clogged or dirty.

**Solution:** Replace part.

### 3. Discharge ball valve stays open.

**A.** Center tube magnet installed upside down, i.e., north and south poles reversed.

**Solution:** Reinstall center tube magnet with white end upward toward valve stem.

**B.** Bleed hole for air cylinder clogged.

**Solution:** Clear bleed hole on top side of air cylinder located on opposite side from control air connection to the cylinder. Do not alter this precision hole diameter.

**C.** Center tube magnet stuck or not properly sealing against valve stem. This can result from excessive oil and water contaminants allowed to get into the control air lines and then into the center tube, thereby coating the center tube magnet and causing it to stick.

**Solution:** Clean center tube interior and center tube magnet and reassemble. Also, if possible, connect the control air line to a clean dry air source which will prevent reoccurrence.

### 4. Excessive bubbling action in reservoir.

**A.** Air leak in balance line and/or fittings.

**Solution:** Refer to installation instructions and start-up procedures.

**B.** Balance line shutoff/isolation valve opened too far.

**Solution:** Adjust valve per installation instructions.



# MODEL 1700™ DIMENSIONAL PRINT

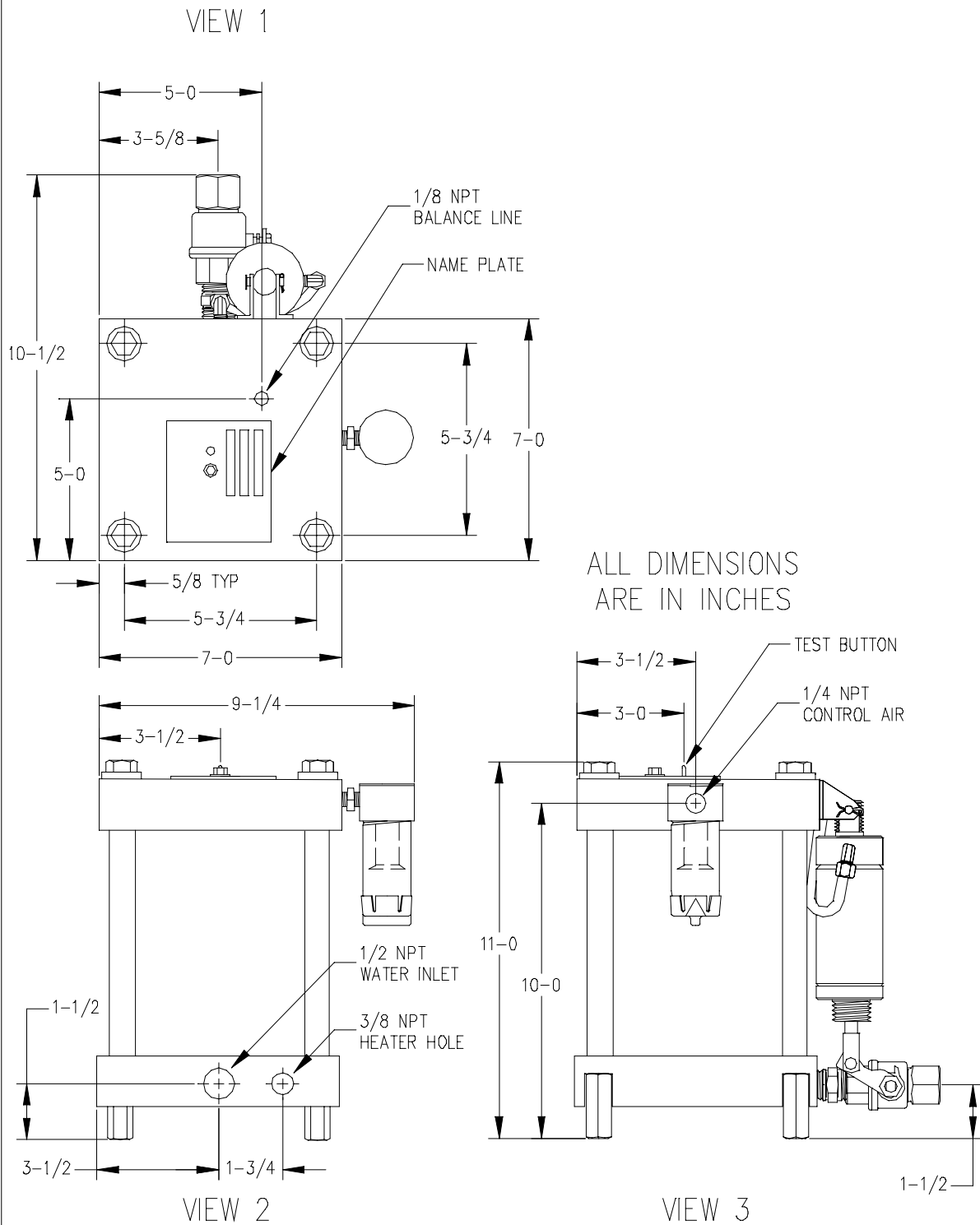

1221981700DP



# PRODUCT TECHNOLOGY

## HOW IT WORKS

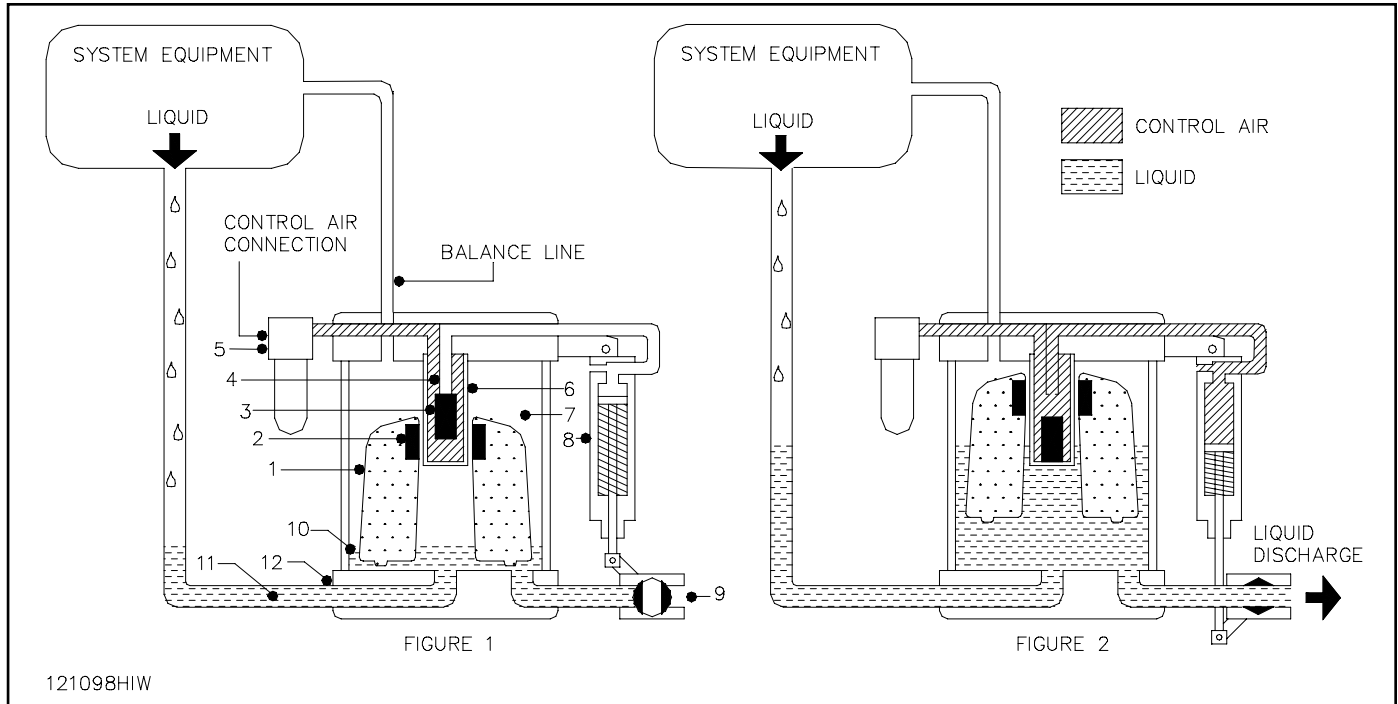

**FIGURE 1: START OF CYCLE**

The float (1) with a magnet molded in (2) is sitting on the base and is at the lowest level. The float magnet exerts a magnetic force repelling the center tube magnet (3) upward, holding it seated against an orifice in the lower end of the valve stem (4). This retains the control air coming in through the control air filter (5) in the center tube (6). The control air circuit including the center tube magnet and valve stem are isolated from the liquid held in the reservoir (7). The air cylinder (8) is in the home position and the discharge ball valve (9) is closed.

There is always a residual amount of liquid (10) left in the bottom of the reservoir after each discharge cycle. The Drain-All stops discharging before all accumulated liquid is removed providing a liquid seal that conserves expensive compressed air. Liquid (11) flows through the inlet port (12) and into the reservoir to start the fill cycle. Liquid continues to fill the reservoir until the float has displaced enough liquid to become buoyant and the float pops upward to the upper position shown in Figure 2.

**FIGURE 2: START OF DISCHARGE**

The liquid flows in and raises the float to its highest position as shown. The float magnet is raised up past the center tube magnet and repels the center tube magnet downward opening the orifice in the valve stem. This allows the control air held in the center tube to flow through the control air circuit to the actuating cylinder. The actuating cylinder extends and opens the discharge ball valve starting the discharge of accumulated liquid.

When the correct amount of liquid has been discharged, leaving a liquid seal in the reservoir, the float has been lowered to a point where the float magnet is below the center tube magnet. In this position, the float magnet repels the center tube magnet back upward against the valve stem orifice, which seals off the control air flow to the actuating cylinder. The cylinder has a spring which then returns the cylinder to its home position, closing the discharge ball valve. The discharge is stopped as shown in Figure 1 and the fill cycle repeats.

**THE BALANCE LINE PORT**

The balance line port is a hole through the head of the Drain-All that goes into the reservoir. This port allows the air trapped in the top of the reservoir to move out of the reservoir to allow liquid to enter the reservoir through the inlet port. If there were no balance line port, as liquid entered the reservoir under pressure, the air trapped in the top of the reservoir would be compressed until it was the same pressure as the liquid coming in and the unit would stop filling.

There are three methods of connecting to the balance line port. The most effective is to connect it back to the vessel being drained as shown in the illustrations above. In this configuration, the reservoir is at the same pressure as the vessel being drained and the liquid is filling by gravity. In this case, the top of the Drain-All must be lower than the bottom of the vessel being drained. The balance line can also be attached to a header pipe leaving the vessel being drained or vented to atmosphere using a shutoff/isolation valve. Venting to atmosphere uses very little air if the needle valve is adjusted properly.



# MODEL 1700™ COMPONENT PARTS DRAWING

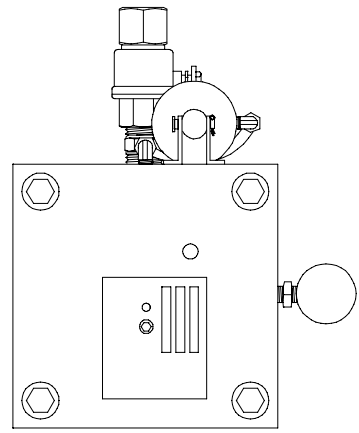
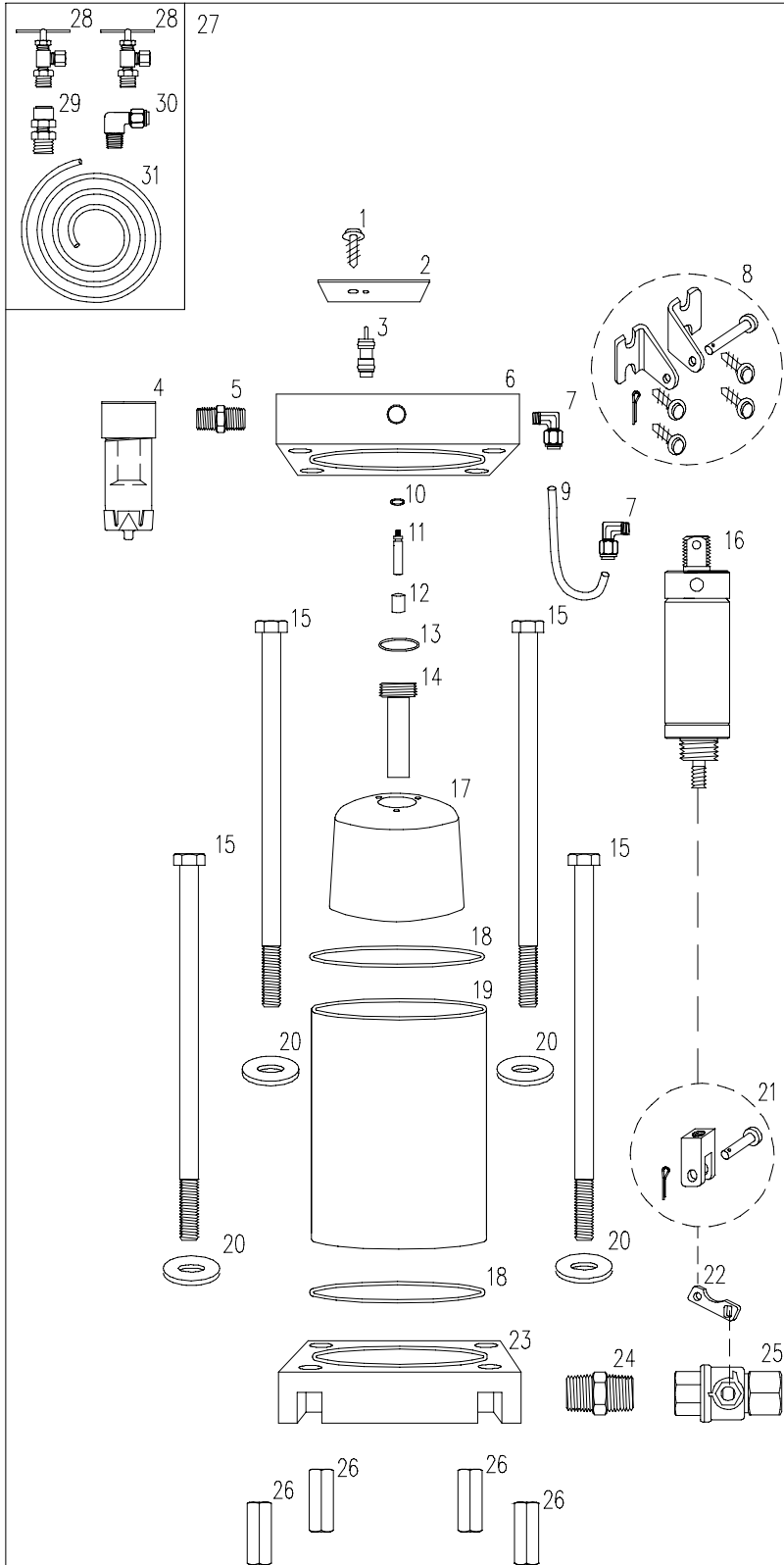

VIEW 1

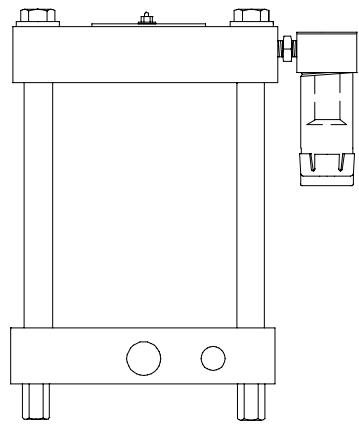

VIEW 2

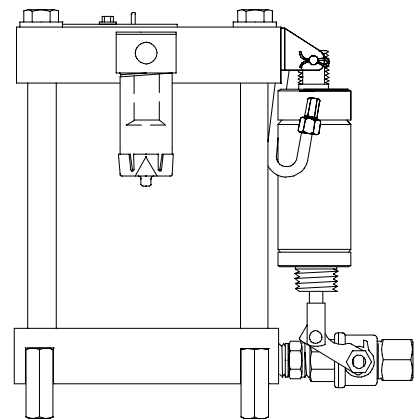

VIEW 3

DETAILED DIMENSIONS ARE  
IN DIMENSIONAL PRINT  
DRAWING

0502051700EXP



# MODEL 1700™

## PARTS & MATERIALS OF CONSTRUCTION

CODE	PART #	ITEM	DESCRIPTION/REMARKS	Qty
1	302500	Screw, Self-Tapping, #10 x 5/8" L	Zinc Plated Steel	1
2	302806	Name Plate	Aluminum	1
3	300600	Push to Test Button, 0.380" Dia x 1.265" L	Brass	1
4	300700	Control Air Filter Assembly, 1/4" NPT	Aluminum Head, Polycarbonate Bowl, Push Drain	1
5	300800	Hex Nipple, 1/4" NPT, 1-1/8" L	Brass	1
6	170100	Head, 7"x7"x1-1/2", 0.150" Groove	6061-T6 Aluminum	1
7	301000	Elbow Fitting, 1/8" NPT - 1/4" Tube	Brass	2
8	300301	Cylinder Mount Kit	Includes:	1
			(2) Brackets-Electroless Nickel Plated Steel	
			(4) Screws-Zinc Plated Steel	
			(1) Mount Pin-Electroless Nickel Plated Steel	
			(1) Cotter Pin-Stainless Steel	
9	350352	Control Air Tube, 1/4" Dia x 7" L	Nylon	1
10	302210	Valve Stem O-ring, 0.235" ID x 0.069" T	Viton, Brown	1
11	100730	Valve Stem, 0.363" Dia x 2.235" L	O-ring Seal, 6061-T6 Aluminum	1
12	400100	Inner Magnet, 0.895" Dia x 1.450" L	Ceramic with Viton Ends and Covering	1
13	302215	Center Tube O-ring, 1.096" ID x 0.069" T	Viton, Brown	1
14	200170	Center Tube, 1.150" Dia x 4.500" L	O-ring Seal, 6061-T6 Aluminum	1
15	302270	Hex Bolt, 1/2" - 13 x 10" L	Zinc Plated Steel	4
16	300314	Pneumatic Cylinder, 2" Dia	40 - 130 PSI, Stainless Steel Body and Rod, Aluminum Ends	1
17	100480	Float, 22.5 to 24 ounces	Polyurethane, Bullet Shaped	1
18	302200	Sleeve O-ring, 5.519" ID x 0.137" T	Viton, Brown	2
19	100300	Sleeve, 6" ID x 7" L x .125" T	Epoxy Fiberglass, Translucent	1
20	301570	Washer, 1/2" SAE	Zinc Plated Steel	4
21	300292	Clevis and Pin Kit	Includes:	1
			(1) Clevis-Electroless Nickel Plated Steel	
			(1) Clevis Pin-Electroless Nickel Plated Steel	
			(1) Cotter Pin-Stainless Steel	
22	100800	Control Lever, 1.625" Long	Stainless Steel for 1/2" NPT Ball Valve	1
23	170200	Base, 7"x7"x1-1/2", 1/2" NPT, 0.150" Groove	6061-T6 Aluminum	1
24	300900	Hex Nipple, 1/2" NPT, 1-1/2" L	Brass	1
25	300205	Heavy Duty Ball Valve, 1/2" NPT	Double O-ring Viton Stem Seals, Nickel Plated	1
26	302370	Coupling Nut, 1/2" - 13 x 1-3/4" L	Zinc Plated Steel	4
27	301130	Installation Kit	Includes:	1
28			(2) Needle Valve-Brass	
29			(1) Straight Fitting-Brass	
30			(1) Elbow Fitting-Brass	
31			(1) 24' - 1/4" Dia LDPE Tube	



## FREQUENTLY ASKED QUESTIONS

### **Where should a Drain-All be installed?**

At liquid accumulation points within a system at compressors, air receiver tanks, intercoolers, aftercoolers, dryers, separators, filters and drip legs.

### **Is this an oil-water separator?**

No. Drain-All is a liquid drain and it will drain oil, water, and particulates from the compressed air system. Once this is accomplished, the discharge should be piped to an oil-water separator for final processing.

### **Does this replace a dryer?**

No. Drain-All works in conjunction with a dryer. Dryers typically convert water vapor in the compressed air into liquid which is usually discharged through a small automatic drain device integral to the dryer. These small automatic drains are often prone to clogging and failure. When this occurs, such drains are normally replaced with Drain-All units which do not clog. A dryer prepares the moisture for removal from the system by condensing it. It is the job of the reliable Drain-All to ensure that the liquid is actually discharged from the air system.

### **Is it mandatory to use a balance line?**

Yes. The balance line provides a means to handle the displaced air from the reservoir as the liquid enters the reservoir.

### **What is the capacity?**

In each application, based on pressures and piping layout for that application, a Drain-All model will eject a specific amount of liquid on each cycle. This varies by model and application.

### **What size compressor can it handle?**

There are Drain-All models that will function effectively on any size compressor, compressed air system, atmospheric, or vacuum system. Provide your distributor with specifications on the pressure and capacity of liquid you need to handle and an appropriately sized Drain-All can be selected for your application.

### **Can one Drain-All be used to drain multiple tanks and/or compressor systems?**

No. They will not all be of precisely the same pressure level and the liquid would accumulate in the lowest pressure drain or system thereby bypassing the Drain-All. Also, the use of check valves in multiple drains to one Drain-All installation will not make this work properly. Always install one Drain-All for each item of equipment to be drained.

### **Can a Drain-All be used in systems with pressure greater than 170 PSIG?**

Yes. Higher pressure models are available. If the control air comes from higher pressure systems, a pressure regulator on the control air line may be used and set at the proper control air pressure or optional control air components can be ordered to accommodate higher pressures.

### **Can the balance line and the control air line be hooked together via a tee connection?**

No. Do not do this. Each of these air lines has its own specific purpose and should never be tied together. The control air should be the cleanest driest air available since it supplies air to the control circuit to operate the pneumatic actuating cylinder which functions best and lasts longer if clean dry air is used.

The balance line allows the air in the reservoir to move out leaving room in the reservoir for the incoming liquid. This air contains moisture that would be drawn across a tee fitting tied to the control air line and be pulled directly into the control air circuit, which can damage control air pathways and the air cylinder.

### **Is there only one model Drain-All?**

No. There are models for a wide range of special applications. Dimensional alterations, design changes, component options and special materials or coatings are used in models to withstand high temperatures and highly corrosive environments as well as accommodate high volume discharge requirements.

### **What if the system has an abundance of metallic trash?**

Before installing the Drain-All, blow down the system being drained to eliminate as much existing loose scale as possible. The large, smoothly contoured flow paths in Drain-All units handle normal levels of debris found in most applications. Should there be an excessive amount of debris such as heavy rust, ask your distributor about Drain-All's Rust Handler™ Model designed for that kind of severe duty.

### **How can the Drain-All be used as an instrument to gather data on condensation in a compressed air system?**

With the use of Drain-All's optional cycle counter, the Drain-All can provide accurate data on the amount of liquid that a compressed air system generates. This is very useful when buying new compressed air system equipment because a Drain-All with a cycle counter is a benchmarking instrument. Since the Drain-All discharges the same amount of liquid on every cycle, knowing the number of cycles over a specific period of time under specific temperature and humidity conditions provides the ability to track liquid production. This benchmarking can be correlated to ongoing changes in ambient temperature and humidity conditions to identify variances in liquid production indicating changes which need investigation. Too few cycles would mean not enough liquid is reaching the Drain-All and should be investigated. Too many cycles would mean too much liquid is being made or too much liquid from somewhere is reaching the Drain-All and should be investigated. Knowing the amount of liquid a system produces is also essential for properly sizing oil-water separators.



# DRAIN-ALL SOLVES PROBLEMS

## **CLOGGED DRAINS**

Other drain devices with small orifices and poppet style valves are prone to clog when solid debris is present. Each Drain-All has a large, smooth liquid flow path and discharge port as well as a heavy duty shear action discharge ball valve designed to alleviate this problem.

## **ELECTRICITY**

Timer valves require electricity. There is a cost for installing and maintaining the electric outlets they require as well an ongoing operating cost of electricity year after year. Drain-All requires no electricity to operate since it is totally pneumatic and can be easily installed at any point along the compressed air system providing low cost installation and ongoing operation.

## **RELIABILITY**

Drain-All's cycling is controlled by a patented magnetic interaction with a totally pneumatic control air circuit. While other pneumatic drains have a complex lever action "toilet bowl" type internal float with many parts, there are few moving parts in the Drain-All. Since the Drain-All is totally pneumatic, it is not affected by power outages or the other vulnerabilities of electrical devices such as timer solenoid valves, motorized ball valves or electrically operated float traps.

## **BYPASSED DRAINS**

Smaller drains become clogged so often that cleaning them out becomes a very labor intensive operation. To avoid constant cleaning, there is a temptation to bypass the inadequate drain and crack open a manual bypass valve causing it to drain constantly thus causing a constant flow of wasted compressed air. Drain-All's anti-clog design eliminates the temptation to bypass the drain.

## **SYSTEM BLOW DOWN**

Manually operated drains, timer solenoid valves, motorized ball valves or electrically operated float traps blow away large quantities of expensive compressed air. Manually operated drains waste consid-

erable compressed air because most operators feel it is necessary to have the drain open an extended period of time in order to get all the liquid out. Timer valves are almost always set to be open longer than necessary in order to get all of the liquid out and this also passes large quantities of compressed air down the drain. Drain-All avoids this waste of compressed air and the resulting pressure drop in the compressed air system by maintaining a liquid seal in the bottom of the Drain-All's reservoir between each cycle.

## **AMOUNT OF LIQUID**

Manual draining and timer valve draining do not provide any information on the quantity of liquid being produced in the compressed air system.

Each Drain-All model discharges a specific amount of liquid on each cycle in a given application. With the addition of a Drain-All cycle counter on the Drain-All unit, it is easy to track how much liquid is produced over any period of time. This is particularly important for benchmarking system equipment performance and performing trend analysis. For example, it is essential to know the quantity of liquid produced by a compressed air system to properly size oil-water separators.

The counter coupled with a Drain-All unit is an instrument. Once installed, it provides tracking of the number of cycles for periods of time at different ambient temperature and humidity conditions. This data can be plotted on a chart. During operations thereafter, a check on the number of cycles per time period of actual operation compared to the chart for a given temperature and humidity will show if the correct amount of liquid is being received by the Drain-All. Too many cycles compared to the chart indicates excessive liquid is being produced somehow and should be investigated. Too few cycles indicates that not enough liquid is being produced and this too should be investigated.

## **OVER-DRAINING**

Manual drain valve operation and timer valves are usually set for overkill in frequency and duration of drainage times in order to be certain that no liquid accumulates in the system. This results in waste of expensive compressed air. Drain-All is demand activated and drains only when the liquid reaches the predetermined trigger point. The Drain-All does not over-drain or blow down the system.

## **UNDER-DRAINING**

Timer drains must be preset to establish the frequency and duration of drainage. The settings are vastly different in periods of high humidity from what they would be in periods of low humidity. It is common for this adjustment to be overlooked in the transition from winter to summer. Therefore, the settings are inadequate to handle the high summer quantities of liquid which results in excess liquid accumulation in the compressed air system. This liquid often backs up and can cause damage to dryers, compressors and hand tools that are expensive to repair. The Drain-All is designed to cycle as needed when liquid accumulates and requires no adjustments from season to season.

## **LIQUID REMOVAL**

The air pressure in the system being drained forces the liquid out of the Drain-All reservoir. Because the power of the air system is behind it, the discharge can be directed upward, to a containment vessel, oil-water separator or an overhead discharge piping system.

### **Drain-All's are:**

#### **Automatic**

No timers, work on demand

#### **Pneumatic**

Totally air operated

#### **Energy Efficient**

Save valuable system pressure

#### **Reliable**

Robust, with few moving parts

#### **Easily Installed**

Simple pipe connection

#### **Adaptable**

Special models for all applications



# TEAM™ DRAIN-ALL

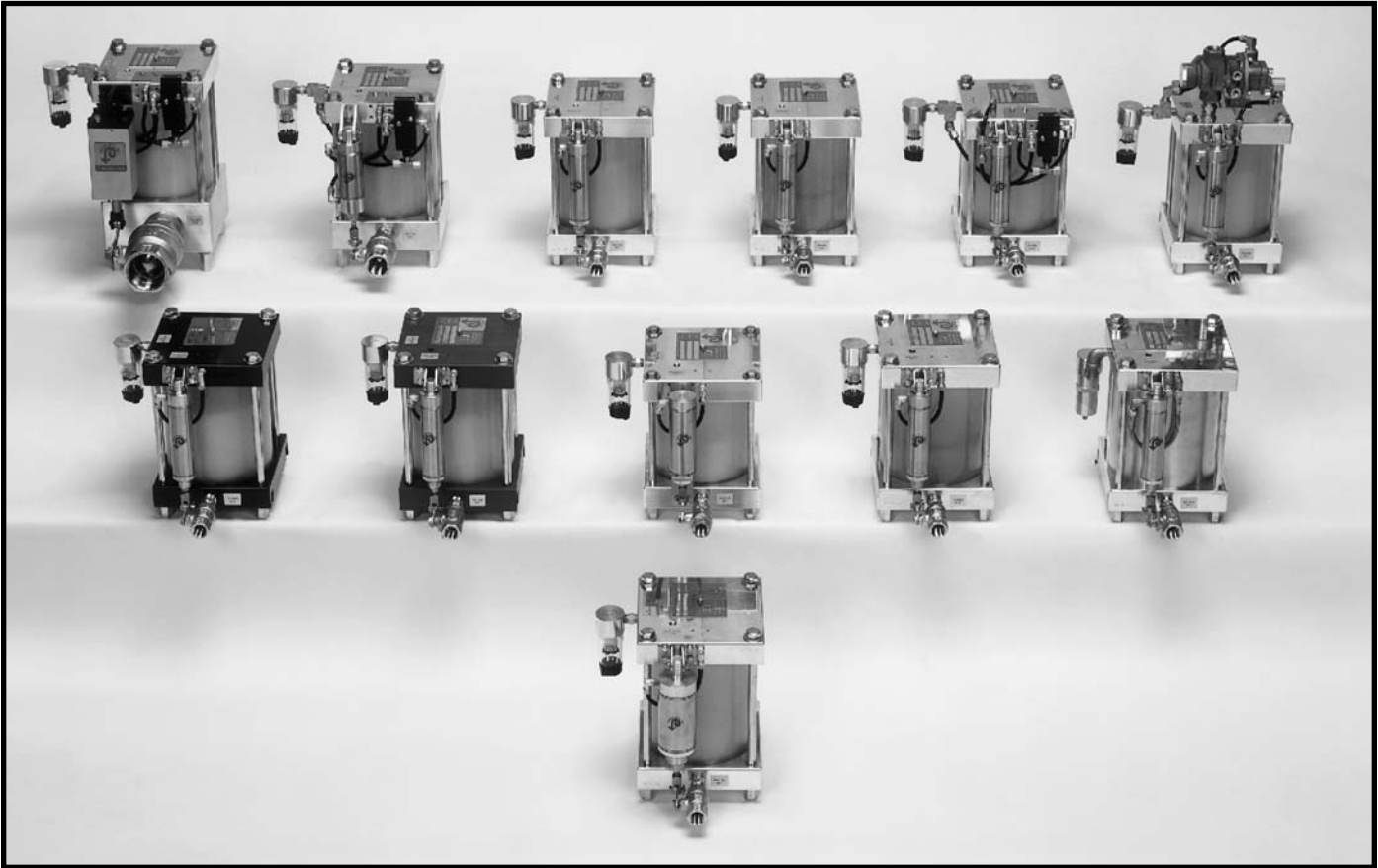

Drain-All, Inc. is an engineering, manufacturing and marketing company with an ISO 9001:2000 certified quality system. Drain-All, Inc. provides unique, high quality, reliable product solutions for draining and moving liquids such as: (1) condensate removal from compressed air systems, (2) oils and lubricants from manufacturing, processing or test equipment, and (3) liquids from atmospheric and vacuum systems. These patented devices are backed by an excellent warranty.

The Drain-All, Inc. technical support team is available to assist customers in applying the wide array of Drain-All, Inc. products, options and accessories in developing engineered solutions for liquid drainage problems.

Shown in the photo above are a few of Drain-All, Inc.'s standard Product Groups. The Model 1700™ (center fore-

ground in the photo above) is Drain-All, Inc.'s flagship product used in facilities around the world to remove liquid from compressed air system applications.

**MODEL™  
1700**  
**CORROSION™**  
*handler*  
**PRESSURE™**  
*handler*  
**RUST™**  
*handler*  
**TEMPERATURE™**  
*handler*  
**VACUUM™**  
*handler*  
**VOLUME™**  
*handler*

In addition to the Model 1700™ there are other Product Groups that can include different models for specific requirements.

There are also situations where specific applications require the use of components, materials of construction and/or design elements from more than one Product Group. These "Special Products" can be quoted upon request. Drain-All, Inc. will evaluate your application requirements and provide a cost for an appropriate product solution.

Visit Drain-All, Inc. on the Internet at:

[www.Drain-All.com](http://www.Drain-All.com)

At the web site you can find out about the specifications for many of Drain-All's standard models, the technology about how they work, and how to submit inquiries about specific application requirements.



# WARRANTY REGISTRATION REQUIRED

## FAX TO: 865-977-6658

Fill in the form below and keep it in this Installation Guide as your record. Make a copy to fax to Drain-All.

Drain-All Serial Number : \_\_\_\_\_ Product Name: \_\_\_\_\_  
Options Included in Product - See Label : \_\_\_\_\_  
Company Name: \_\_\_\_\_  
Street Address: \_\_\_\_\_  
City: \_\_\_\_\_ State: \_\_\_\_\_ Zip: \_\_\_\_\_  
Requisitioned By: \_\_\_\_\_ Title: \_\_\_\_\_  
Installed By: \_\_\_\_\_ Title: \_\_\_\_\_  
Date Installed: Month: \_\_\_\_\_ Day: \_\_\_\_\_ Year: \_\_\_\_\_  
Installed on Type Equip: \_\_\_\_\_  
Brand: \_\_\_\_\_ Size/Rating: \_\_\_\_\_  
Purchased From: Company Name: \_\_\_\_\_  
City: \_\_\_\_\_ State: \_\_\_\_\_ Phone: \_\_\_\_\_ Fax: \_\_\_\_\_

**I want to receive free technical bulletins and newsletters:** YES \_\_\_\_\_ NO \_\_\_\_\_  
If yes, provide: Your name: \_\_\_\_\_ Title: \_\_\_\_\_  
Company: \_\_\_\_\_ Phone: \_\_\_\_\_ Fax: \_\_\_\_\_  
Street Address: \_\_\_\_\_ Mail Stop: \_\_\_\_\_  
City: \_\_\_\_\_ State: \_\_\_\_\_ Zip: \_\_\_\_\_

## WARRANTY

Drain-All, Inc. warrants to purchaser that the product is free from defects in material and workmanship assuming normal use and service, subject to the terms below.

Drain-All, Inc. shall not be liable under any applicable warranty for normal wear and tear or for any loss or damage whatsoever caused by a user or by the installed environment whether by accident, negligence, abuse, neglect, alteration, disassembly, assembly, installation, operation, repair or maintenance by individuals not authorized by Drain-All, Inc. Specifically excluded are damages which may be caused by salty or other chemically corrosive environments.

This warranty is expressly in lieu of, and excludes, all oral statements or warranties or other written expressed warranties not set forth herein (except as otherwise required by law) and Drain-All, Inc. neither assumes nor authorizes any other person to assume for it any liability or obligation not set forth herein in connection with the sale of goods hereun-

der. This warranty gives purchaser specific legal rights and purchaser may also have other rights which may vary from state to state.

This warranty, and all implied warranties, including merchantability, fitness for a particular purpose or otherwise, commence on the date of shipment by Drain-All, Inc. and are limited to thirty-six (36) months on materials and workmanship and accordingly any such implied warranties, including merchantability, fitness for a particular purpose or otherwise, are disclaimed in their entirety after the expiration of the previously stated warranty period. Some states do not allow limitations on how long an implied warranty lasts, so the above time limitations may not apply to purchaser.

Drain-All, Inc. shall not be liable for incidental, consequential, direct or indirect damages or expenses for breach of warranty, contract, negligence or otherwise arising from the sale, handling or use of the goods, or from any

other cause relating thereto and Drain-All, Inc.'s liability hereunder is expressly limited, at Drain-All, Inc.'s election and cost, to the repair or replacement of the defective part that does not comply with any applicable warranty and shall in no event exceed the original purchase price of the unit. Some states do not allow the exclusion or limitation of incidental or consequential damages, so the above limitation may not apply to purchaser.

All claims under this warranty should be made by contacting the local Drain-All, Inc. representative. Warranty is transferable by notifying Drain-All, Inc. of new owner, address, model and serial number on unit. All warranty related correspondence should be addressed to:



**Drain-All, Inc.**



# INSTALLATION LOCATIONS

**INSTALLATION SCHEMATICS:** The illustration below shows an entire compressed air system installation. This drawing and a set of installation schematics for each station on this system in 8-1/2" by 11" drawings is available from Drain-All, Inc. in PDF file format. Simply forward your email address to TechService@Drain-All.com and ask for Schematic Drawings Set 1.

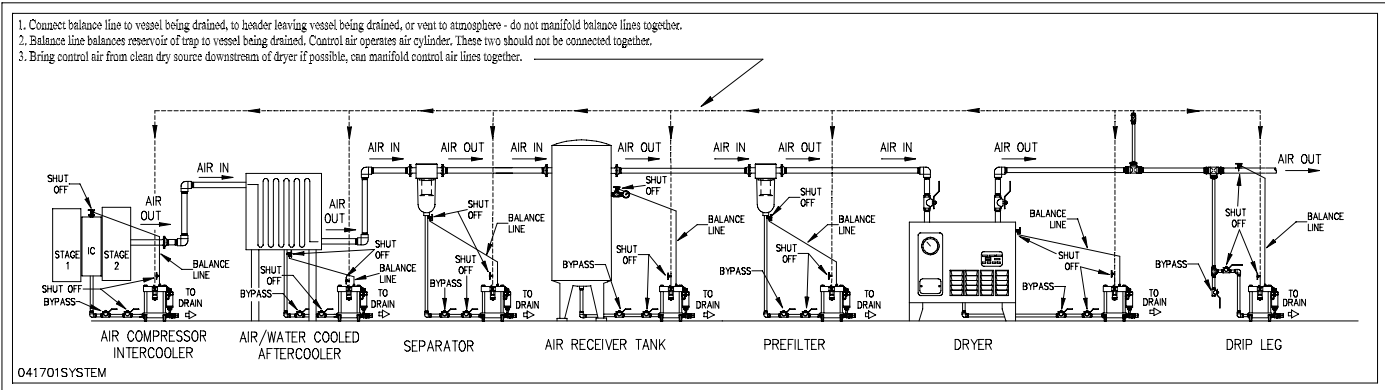

## THERE ARE THREE METHODS USED TO CONNECT THE BALANCE LINE PORT

### Method -1

**Connect the balance line port to the vessel producing the condensate.** This is the preferred method since it is a closed-loop arrangement. In the first four applications above, the balance line is connected back to the vessel that is producing the condensate. The pressure on the incoming condensate to the trap and the pressure in the balance line are the same and the trap is filling by gravity. For this method, the top of the trap must be below the bottom of the vessel being drained.

### Method -2

**Connect the balance line port to the header pipe leaving the vessel producing the condensate.** This is an alternate method to Method-1 when there is no convenient location to connect the balance line to the vessel. This is shown above in the drip leg application. In the case of a dryer, however, connecting the balance line to the header pipe leaving the dryer essentially results in a bypass of the dryer function. The condensate from the dryer would have a path up the balance line and back into the flow of dry air leaving the dryer. That would not be desirable.

### Method -3

**Vent the balance line port to atmosphere using a shutoff/isolation valve inserted in the balance line port and slightly opened.** This can be used on any application but must be used when the bottom of the vessel is lower than the top of the trap. The needle valve should be opened slightly to a point where only a small amount of air can be felt leaving the needle valve. This method provides a pressure differential in the trap reservoir and condensate is blown into the reservoir instead of filling by gravity.

## VESSELS WITH BOTTOM LOWER THAN THE TRAP'S TRIGGER LEVEL

In the drawing below, there is a dotted line indicating the trigger level of the trap. This is the height the condensate must reach in the trap to start the discharge cycle.

When the balance line port is connected back to the vessel or header pipe, as shown in the drawing above, the trap is filling by gravity. In these applications the bottom of the vessel must be higher than the top of the trap so that the condensate flows by gravity down and out of the vessel into the trap.

When the bottom of a vessel being drained is lower than the trigger point in the trap, as shown in the drawing to the right, do not connect the balance line port to the vessel or header pipe.

In the drawing to the right, if the balance line were connected to the vessel or header pipe, the condensate would be filling

the trap by gravity. With the bottom of the vessel being lower than the top of the trap, this would result in condensate backing up in the vessel to the same height of the condensate in the trap. When the condensate reaches

the trigger level in the trap, shown by the dotted line, the condensate also reaches the same height in the vessel (the same dotted line).

In an application where the bottom of the vessel is lower than the top of the trap, the balance line must be vented to atmosphere. Venting a small amount of air from the trap reservoir to atmosphere results in a pressure differential in the trap reservoir. This allows the pressure in the vessel to push the condensate downward, out of the vessel, and up into the trap. This achieves proper filling of the trap while removing all condensate from the vessel. Send application questions to:

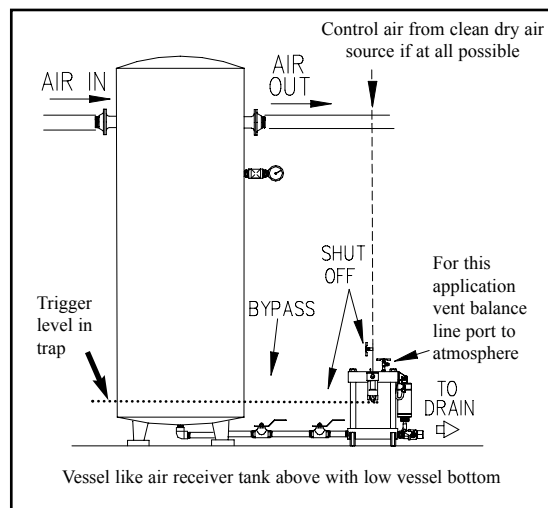

**Ross Brown Sales Pty Ltd**

ABN 28 000 690 362  
Phone: 612 9899 2744 Fax: 612 9899 4233  
Email: [sales@rossbrownsales.com.au](mailto:sales@rossbrownsales.com.au)  
Web: [www.rossbrownsales.com.au](http://www.rossbrownsales.com.au)