



Model: 119678-00 - 7610152
119678-07*

DESCRIPTION

- Two stage
- 240 volts
- 5.7"/ 145 mm diameter
- Dual ball bearings
- Single speed
- Tangential bypass discharge
- Aluminum fan end bracket
- Aluminum commutator bracket

DESIGN APPLICATION

- Equipment operating in environments requiring separation of working air from motor ventilating air
- Designed to handle clean, dry, filtered air only

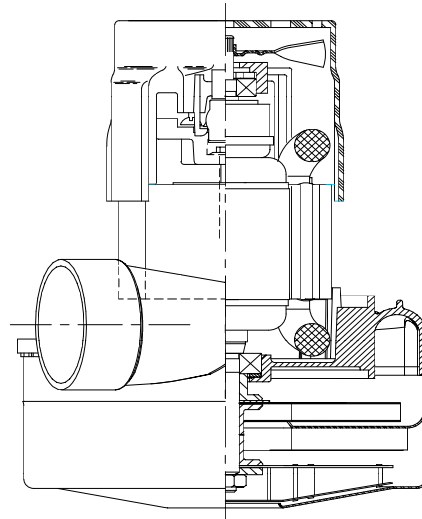

SPECIAL FEATURES

- Suitable for 240 volt AC operation, 50/60 Hz
- UL recognized, category PRGY2 (E47185)
- Provision for grounding
- Skeleton frame design
- Tapered fan system
- The Lamb vacuum motor line offers a wide range of performance levels to meet design needs

* Model -07 is built with terminals



TYPICAL MOTOR PERFORMANCE.*

(At 240 volts, 60Hz, test data is corrected to standard conditions of 29.92 Hg, 68° F.)

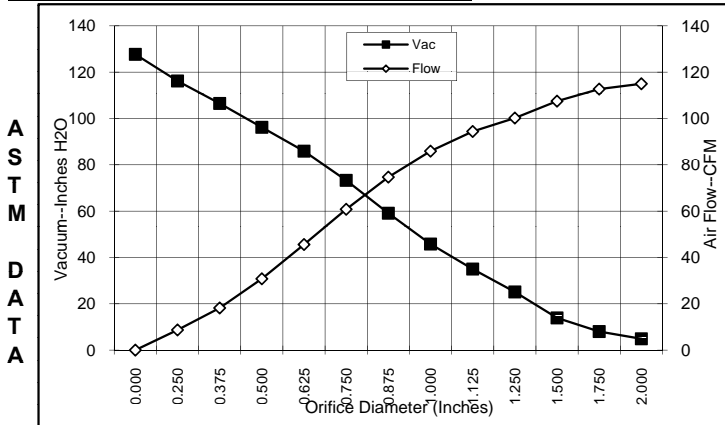

Orifice (Inches)	Amps	Watts (In)	RPM	Vac (In.H2O)	Flow (CFM)	Air Watts
2.000	7.3	1686	22,806	4.9	115.0	66
1.750	7.3	1690	22,806	8.0	112.7	107
1.500	7.3	1690	22,783	13.9	107.5	177
1.250	7.3	1687	22,793	25.1	100.2	296
1.125	7.3	1683	22,840	35.0	94.4	380
1.000	7.2	1672	22,870	45.8	85.9	462
0.875	7.1	1646	23,103	59.1	74.7	519
0.750	6.9	1585	23,513	73.3	60.8	523
0.625	6.5	1497	24,216	85.9	45.6	460
0.500	6.0	1389	25,243	96.2	30.8	348
0.375	5.5	1275	26,346	106.5	18.2	228
0.250	5.0	1163	27,606	116.2	8.7	119
0.000	4.6	1083	28,726	127.7	0.0	0

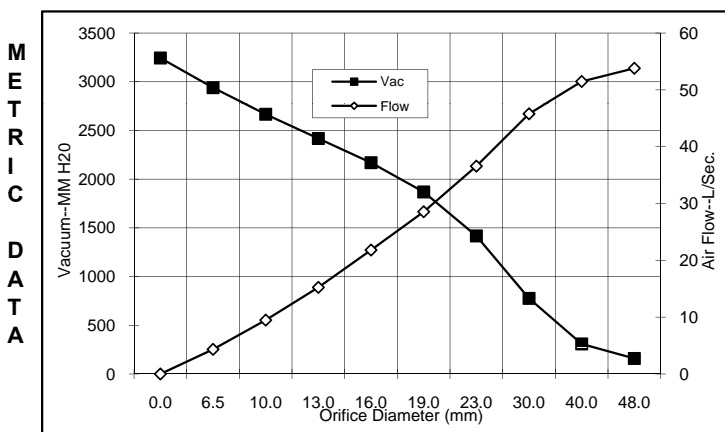

Orifice (mm)	Amps	Watts (In)	RPM	Vac (mm H2O)	Flow (L/Sec)	Air Watts
48.0	7.3	1688	22806	159	53.8	84
40.0	7.3	1690	22790	308	51.5	156
30.0	7.3	1685	22819	776	45.8	342
23.0	7.2	1653	23045	1417	36.6	505
19.0	6.9	1583	23527	1868	28.6	522
16.0	6.5	1501	24188	2169	21.8	463
13.0	6.0	1400	25140	2417	15.2	359
10.0	5.5	1292	26181	2666	9.5	246
6.5	5.0	1169	27543	2939	4.3	124
0.0	4.6	1083	28726	3244	0.0	0

Note: Metric performance data is calculated from the ASTM data above.

* Data represents performance of a typical motor sampled from a large production quantity. Individual motor data may vary to normal manufacturing variations.

Test Specs:	240 Volts	Minimum Sealed Vacuum:	122.0"	ORIFICE: 7/8"	Minimum Vacuum:	56.0"	Maximum Watts:	1709
-------------	-----------	------------------------	--------	---------------	-----------------	-------	----------------	------

DIMENSIONS

Drawing Listed Below Depicts Motor #119678-07 (with terminals)

NOTES:

1. LEADS: 18GA STRANDED, LEADS CAN BE ANY COLOR EXCEPT GREEN OR GREEN WITH YELLOW STRIPE.
2. GROUNDING OR EARTHING PROVISIONS: USE HOLES AS INDICATED FOR GROUNDING OR EARTHING. REFER TO APPROPRIATE LISTING OR REGULATORY AGENCY FOR PROPER METHOD OF GROUNDING OR EARTHING.
3. MOTOR IDENTIFICATION: MANUFACTURER'S NAME, MODEL NUMBER, VOLTAGE, FREQUENCY, INSPECTOR'S CODE, DATE OF MANUFACTURE, AGENCY RECOGNITION CODE, PLANT LOCATION CODE, PATENT INFORMATION, ONE OR MORE OF THE FOLLOWING PATENTS APPLY TO THIS MOTOR: 5482378; 5736805; 4669952; 4684835". AND MADE IN THE USA.
4. ALLOW [0.0016 SQ M]/2.5 SQ IN. MIN. FOR COOLING AIR INTAKE.
5. COOLING AIR INTAKE MUST BE SEPERATED FROM COOLING AIR EXHAUST.
6. VACUUM EXHAUST MUST BE SEPERATED FROM COOLING EXHAUST.
7. MOUNTING MUST NOT RESTRICT THIS DIAMETER.

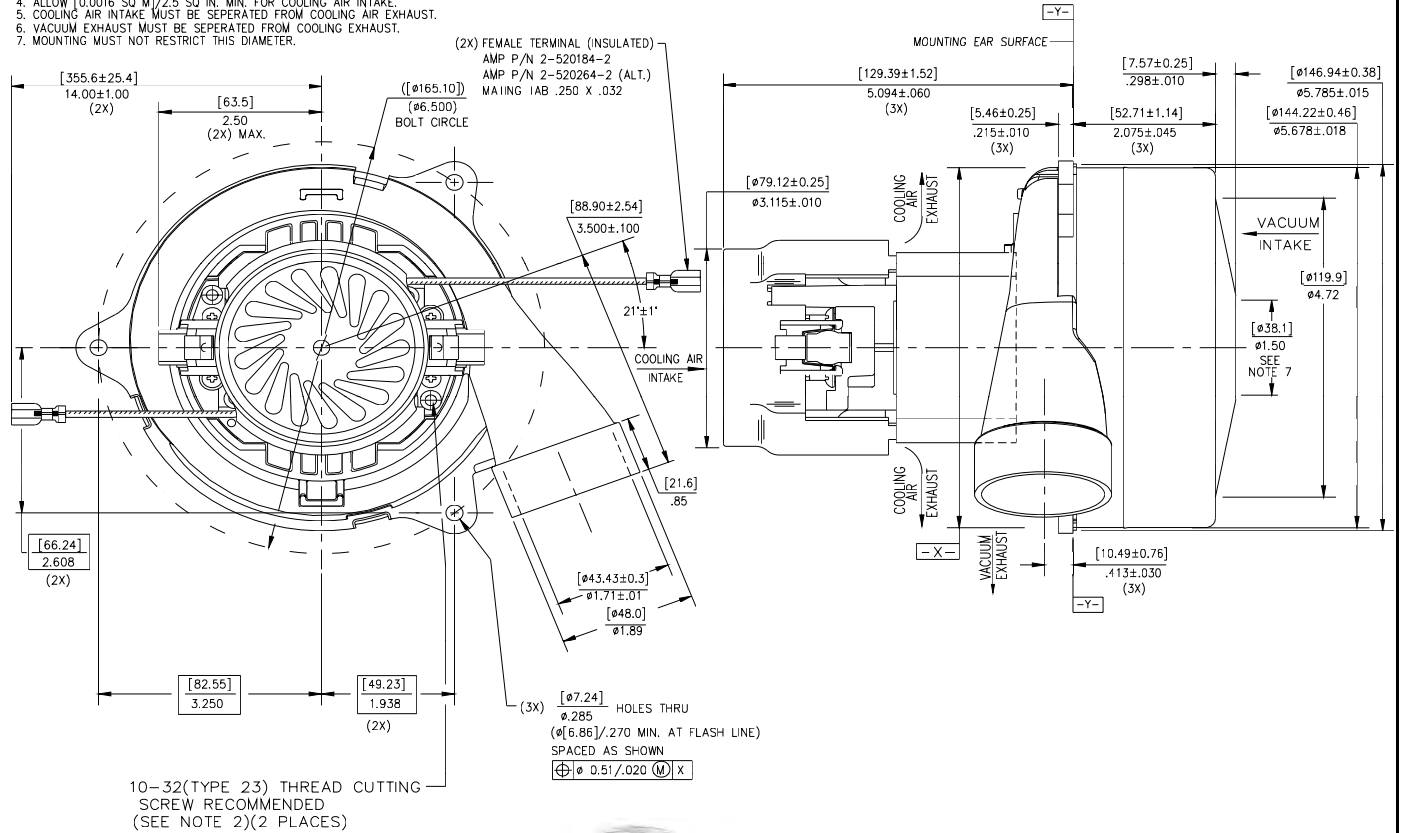

IMPORTANT NOTE: Pictorial and dimensional data are subject to change without notice. Contact factory for current revision levels.

WARNING - When using AMETEK/Lamb Electric bypass motors in machines that come in contact with foam, liquid (including water) of other foreign substances, the machine must be designed and constructed to prevent those substances from reaching the fan system, motor housing and electrical components. Lamb vacuum motors other than hazardous duty models should not be applied in machines that come in contact with dry chemicals or other volatile materials. Failure to observe these precautions could cause flashing (depending on volatility) or electrical shock which could result in property damage and severe bodily injury, including death in extreme cases. All applications incorporating Lamb motors should be submitted to appropriate organizations or agencies for testing specifically related to the safety of your equipment.



Reissued: November, 2003