



Model: 121114-13



DESCRIPTION

- Brushless Motor
- Switch Reluctance (SR) Technology
- Two stage Fan System
- 230 volts, 50/60 Hz (suitable to 240 volts)
- 7.2" / 183 mm diameter
- Dual 10mm ball bearings
- Tangential discharge
- All aluminum die cast housings used in motor construction
- Life expectancy: 5 -10 times more than the brush-motor equivalent.

DESIGN APPLICATION

- Equipment operating in environments requiring separation of working air from motor ventilating air
- Designed to handle clean, dry, filtered air only

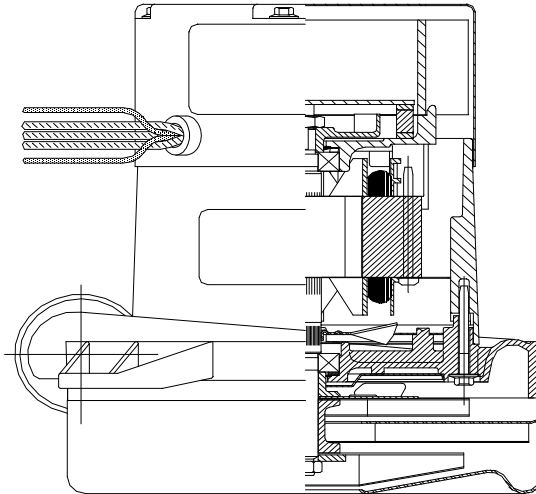

SPECIAL FEATURES

- "Generation II" (DIGITAL) Controller: no external low-voltage control power required. (See "INFIN-A-TEK Application Notes")
- UL component recognized (pending)
- IP Rating: 1.0
- **Speed control capability**
- Tapered fan system
- Thermally protected motor design
- Patented air seal bearing construction (U.S. Patent # 4,088,424)
- Epoxy painted
- Aluminum fan end bracket designed to dampen vibration and improve durability

Please refer to **INFIN-A-TEK Application Notes** for details on the operation and wiring of this switched-reluctance motor.

TYPICAL MOTOR PERFORMANCE.*

(At 230 volts, 60Hz, test data is corrected to standard conditions of 29.92 Hg, 68° F.)

ASTM DATA

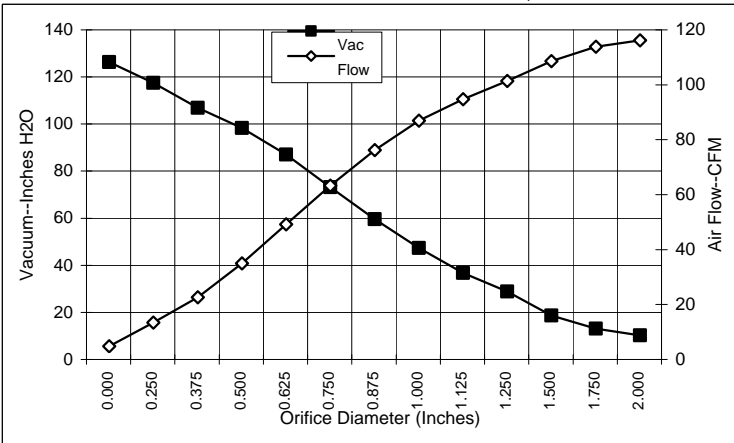

Orifice (Inches)	Amps	Watts (In)	RPM	Vac (In.H2O)	Flow (CFM)	Air Watts
2.000	7.1	1349	21910	4.6	111.4	60
1.750	7.1	1367	21860	7.5	109.1	97
1.500	7.2	1375	21740	13.0	103.8	159
1.250	7.2	1379	21615	23.3	96.6	265
1.125	7.2	1384	21565	31.1	90.0	329
1.000	7.2	1376	21665	41.7	82.1	403
0.875	7.1	1360	21865	54.0	71.4	453
0.750	6.8	1312	22105	67.5	58.5	464
0.625	6.5	1264	22670	81.4	44.4	424
0.500	6.1	1171	23625	92.7	30.2	329
0.375	5.5	1073	24660	101.2	17.8	212
0.250	5.4	1043	26130	111.9	8.6	113
0.000	4.9	964	27000	120.7	0.0	0

METRIC DATA

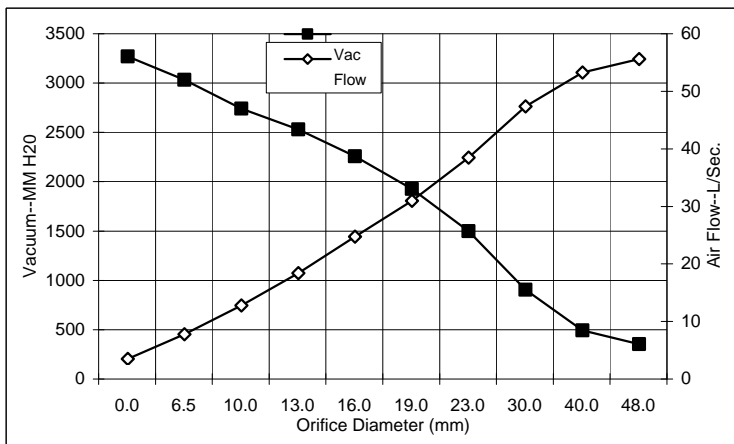

Orifice (mm)	Amps	Watts (In)	RPM	Vac (mm H2O)	Flow (L/Sec)	Air Watts
48.0	7.1	1357	21888	149	52.1	76
40.0	7.2	1373	21776	288	49.7	140
30.0	7.2	1382	21588	701	43.9	300
23.0	7.1	1364	21815	1293	35.0	441
19.0	6.8	1311	22116	1722	27.5	463
16.0	6.5	1266	22647	2053	21.2	426
13.0	6.1	1180	23530	2326	14.9	339
10.0	5.6	1088	24505	2538	9.3	230
6.5	5.4	1045	26057	2829	4.3	118
0.0	4.9	964	27000	3066	0.0	0

Note: Metric performance data is calculated from the ASTM data above.

* Data represents performance of a typical motor sampled from a large production quantity. Individual motor data may vary due to normal manufacturing variances.

Test Specs: 230v	Minimum Sealed Vacuum: 115.0"	ORIFICE: 7/8"	Minimum Vacuum: 52.0"	Maximum Watts: 1418
------------------	-------------------------------	---------------	-----------------------	---------------------



DIMENSIONS

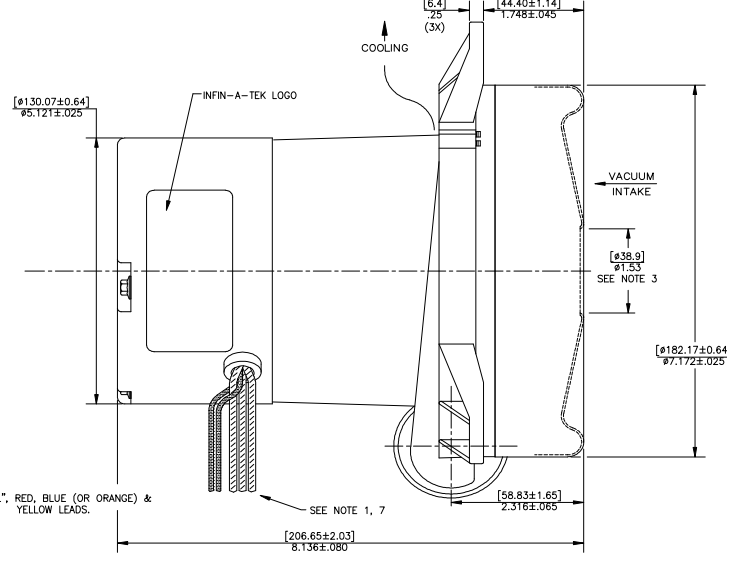
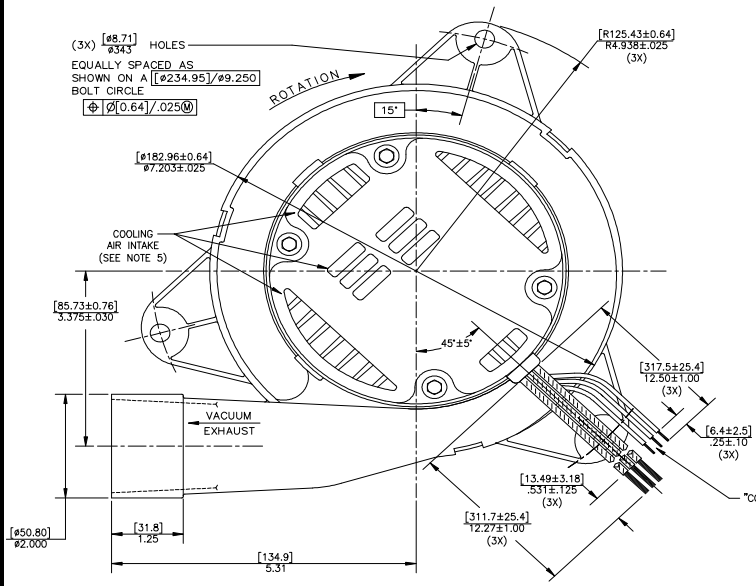

NOTES

1. Leads: 18ga, stranded power leads; one black and one white, ground lead green with yellow stripe.
Leads: 22ga, control leads: one red, one blue (or orange) and one yellow.
2. Motor Identification: Manufacturer's name, model number, voltage, frequency, inspection code, date of manufacture, agency recognition code, plant code, "Thermally Protected L 16.0A", "Made in the USA" and the following information: "Manufactured under patent nos: US5789893, TW81933, SG38957, ZA96/2766, US5760519, EP0702448B1, ZA95/7123 under license from Switched Reluctance Drive Ltd. Other U.S. and foreign patents pending, copyright code 1998, all rights reserved."
3. Mounting must not restrict this diameter.
4. **Allow (0.0026 Sq M) / 4.8" Sq In. (min) for cooling air intake and exhaust.**
5. Cooling air intake must be separated from cooling air exhaust.
6. Cooling air exhaust must be separated from vacuum exhaust.
7. Observe NEC wiring convention (black-line and white neutral) to insure proper placement of control module fuse in the circuit. **See wiring options 1 thru 4 of "INFIN-A-TEK Application Notes" for implementing the "control" feature (red, blue (or orange) & yellow leads).**
8. The INFIN-A-TEK blower utilizes a switched reluctance (SR) brushless motor, which is commutated electronically. Similar to a brush type series universal motor, this INFIN-A-TEK (SR) blower operates on AC voltage. The INFIN-A-TEK (SR) blower features an integral electronic control module that rectifies the "AC line voltage" to obtain the DC voltage required to power the motor. All switched reluctance motors are thermally protected using an auto-reset device.

IMPORTANT NOTES: Pictorial and dimensional data are subject to change without notice. Contact factory for current revision levels.

WARNING - When using AMETEK/Lamb Electric bypass motors in machines that come in contact with foam, liquid (including water) or other foreign substances, the machine must be designed and constructed to prevent those substances from reaching the fan system, motor housing and electrical components. Lamb vacuum motors other than hazardous duty models should not be applied in machines that come in contact with dry chemicals or other volatile materials. Failure to observe these precautions could cause flashing (depending on volatility) or electrical shock which could result in property damage and severe bodily injury, including death in extreme cases. All applications incorporating Lamb motors should be submitted to appropriate organizations or agencies for testing specifically related to the safety of your equipment.