



**Advantek II - Ultra**



**DESCRIPTION**

- Two stage
- 240 volts
- 5.7"/145 mm diameter
- Double ball bearings
- Single speed
- Thru-flow discharge
- Thermoset fan end bracket
- Stamped steel end bracket

**DESIGN APPLICATION**

- Equipment operating in environments not requiring separation of working air from motor ventilating air
- Designed to handle clean, dry, filtered air only

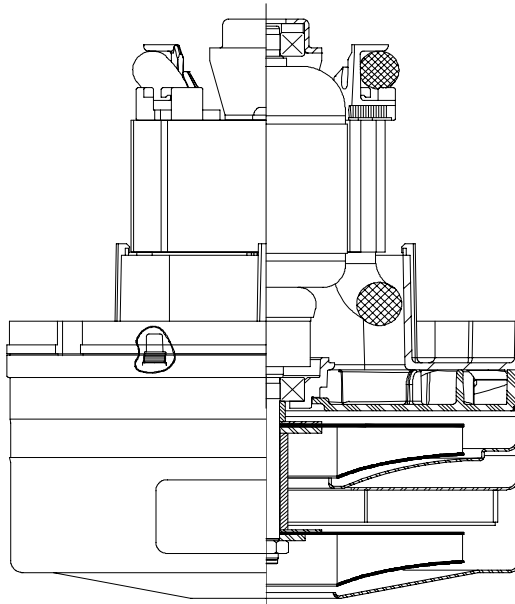

**SPECIAL FEATURES**

- 660 **Peak Air Watts**
- Patented Advantek II diffusion
- 3" Commercial Lamination
- Dual Tapered fan system
- Provision for grounding
- Top end mounting boss
- Thermal Device
- UL recognized, category PRGY2 (E47185)
- Suitable for 120 volt AC operation, 50 or 60 Hz
- The Lamb vacuum motor line offers a wide range of performance levels to meet design needs

**PEAK AIRWATTS**  
**660**  
Calculated in accordance with ASTM

**TYPICAL MOTOR PERFORMANCE.\***

(At 240 volts, 60Hz, test data is corrected to standard conditions of 29.92 Hg, 68° F.)

**ASTM DATA**

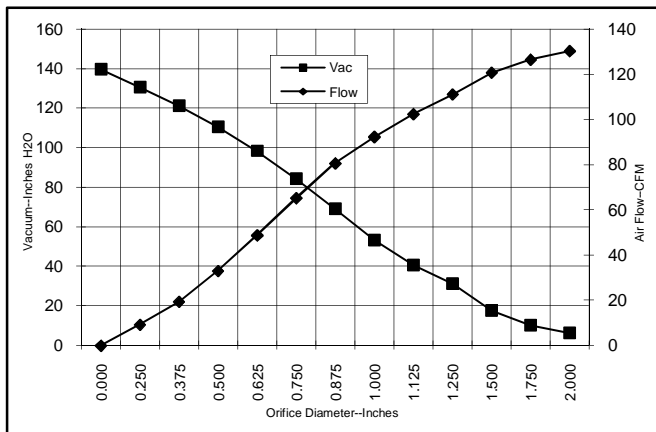

Orifice (Inches)	Amps	Watts (In)	RPM	Vac (In.H <sub>2</sub> O)	Flow (CFM)	Air Watts
2.000	7.4	1682	25600	6.3	130.2	96
1.750	7.4	1684	25600	10.3	126.4	152
1.500	7.3	1673	25600	17.7	120.6	252
1.250	7.3	1662	25990	31.2	111.1	408
1.125	7.2	1649	25990	40.6	102.3	489
1.000	7.1	1630	25980	53.2	92.2	577
0.875	7.0	1596	26380	69.1	80.6	654
0.750	6.6	1516	26770	84.3	65.2	647
0.625	6.1	1418	27940	98.3	48.7	564
0.500	5.6	1291	29130	110.4	33.0	428
0.375	5.0	1155	30700	121.1	19.4	276
0.250	4.5	1048	32270	130.5	9.2	142
0.000	4.1	971	33450	139.7	0.0	0

**METRIC DATA**

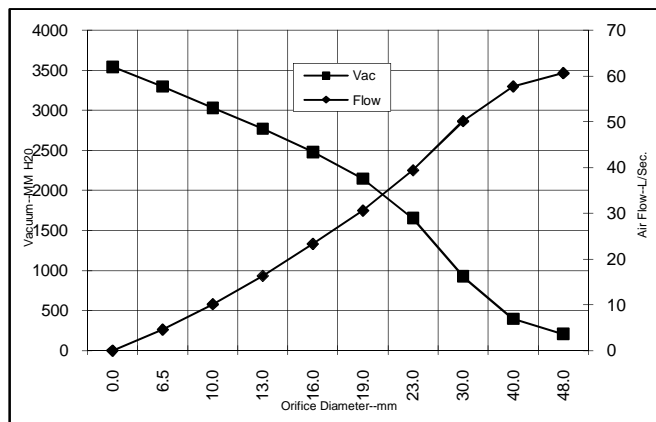

Orifice (mm)	Amps	Watts (In)	RPM	Vac (mm H <sub>2</sub> O)	Flow (L/Sec)	Air Watts
48.0	7.4	1683	25600	204	60.7	121
40.0	7.3	1676	25600	393	57.7	222
30.0	7.2	1655	25990	924	50.2	452
23.0	7.0	1605	26280	1653	39.4	635
19.0	6.6	1514	26793	2149	30.6	645
16.0	6.2	1422	27893	2484	23.3	567
13.0	5.6	1304	29011	2774	16.3	442
10.0	5.0	1175	30465	3036	10.1	299
6.5	4.5	1053	32192	3302	4.6	148
0.0	4.1	971	33450	3548	0.0	0

Note: Metric Performance data is calculated from the ASTM data above.

\* Data represents performance of a typical motor sampled from a large production quantity. Individual motor data may vary due to normal manufacturing variations

Test Specs:	240 volts	Minimum Sealed Vacuum:	130.0	ORIFICE:	7/8 "	Minimum Vacuum:	63.0	Maximum Watts:	1700
-------------	-----------	------------------------	-------	----------	-------	-----------------	------	----------------	------



**Ross Brown Sales Pty Ltd**

ABN 28 000 690 362  
Phone: 612 9899 2744 Fax: 612 9899 4233  
Email: [sales@rossbrownsales.com.au](mailto:sales@rossbrownsales.com.au)  
Web: [www.rossbrownsales.com.au](http://www.rossbrownsales.com.au)



**DIMENSIONS**

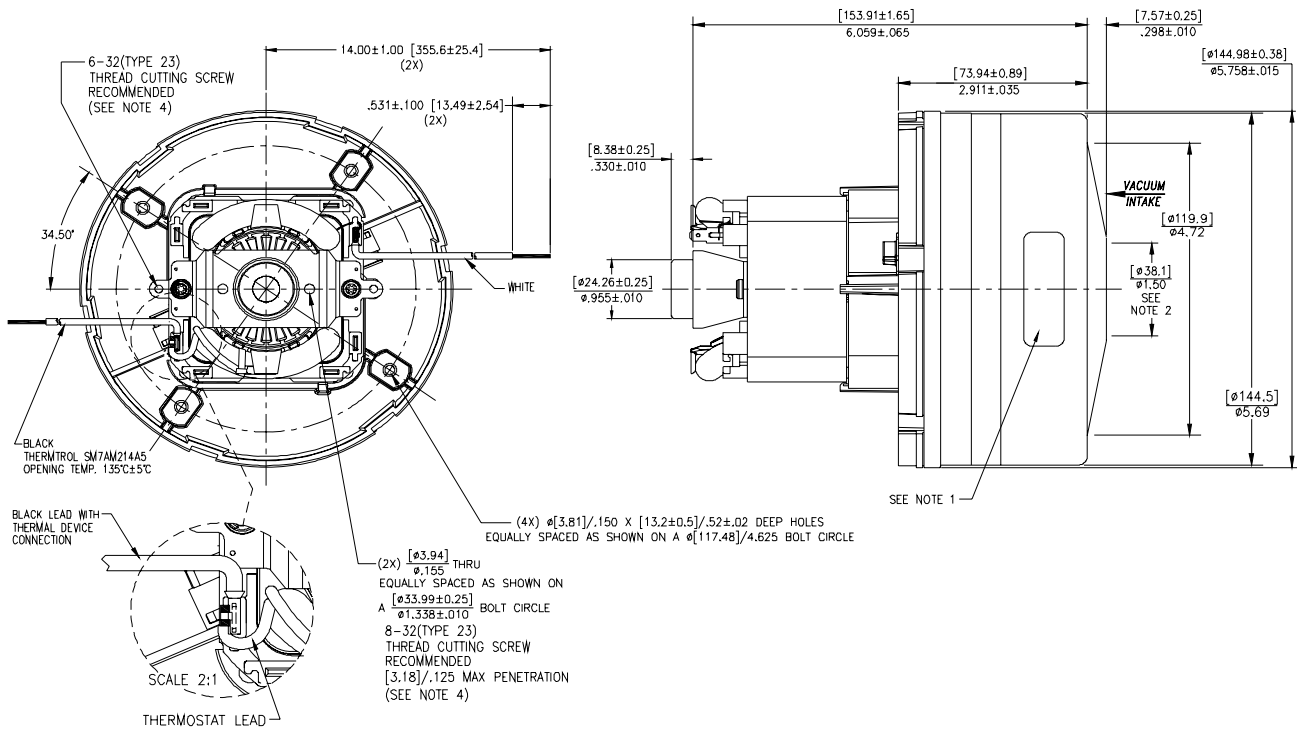

**Advantek II - Ultra**

**IMPORTANT NOTE:** Pictorial and dimensional data are subject to change without notice. Contact factory for current revision levels.

**WARNING -** AMETEK Lamb Electric thru-flow vacuum motors must never be used in applications in which wet or moist conditions are involved, where dry chemicals or other volatile materials are present, or where airflow may be restricted or blocked. Such motors are designed to permit the vacuumed air to pass over the electrical winding to cool it. Thus any foam, liquid (including water), dry chemical, or other foreign substance coming in contact with electrical conductors could cause combustion (depending on volatility) or electrical shock. Failure to observe these precautions could result in property damage and severe personal injury, including death in extreme cases. All applications incorporating Lamb Electric motors should be submitted to Underwriters Laboratories Inc or other appropriate organizations or agencies for testing specifically related to the safety of your equipment.

**AMETEK/Lamb Electric Division**  
 627 Lake Street  
 Kent, Ohio 44240  
 U.S.A.  
 Tel: (330) 673-3786 Fax: (330) 677-3812  
 www.lambelectric.com