



Advantek II - Plus

DESCRIPTION

- Single stage
- 240 volts
- 5.7"/145 mm diameter
- Double ball bearings
- Single speed
- Thru-flow discharge
- Thermo-set fan end bracket
- Stamped steel end bracket

DESIGN APPLICATION

- Equipment operating in environments not requiring separation of working air from motor ventilating air
- Designed to handle clean, dry, filtered air only

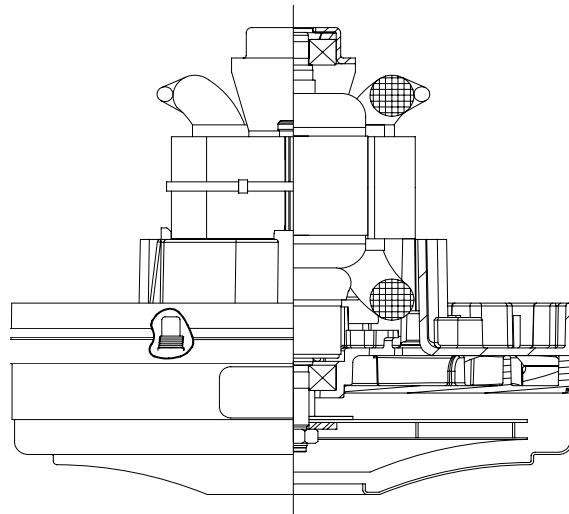

SPECIAL FEATURES

- Suitable for 240 volt AC operation, 60 Hz
- UL recognized, category PRGY2 (E47185)
- CSA certified, class 1611 01 (LR31393)
- Provision for grounding
- Skeleton-frame construction
- **Patented Advantek II diffusion**
- **Tapered high efficiency fan system**
- The Lamb vacuum motor line offers a wide range of performance levels to meet design needs



TYPICAL MOTOR PERFORMANCE.*

(At 250 volts, 60Hz, test data is corrected to standard conditions of 29.92 Hg, 68° F.)

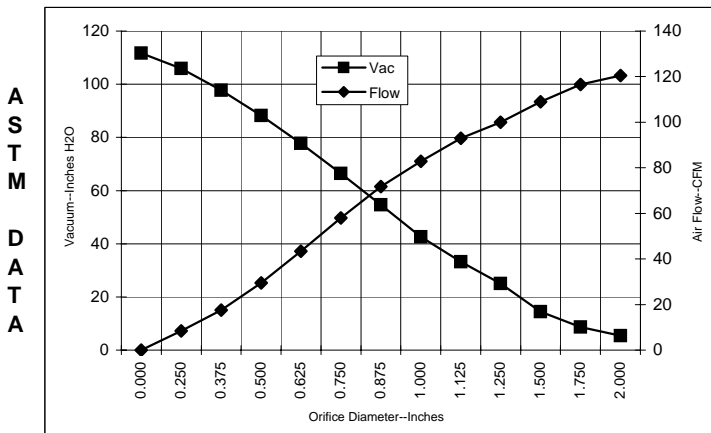

Orifice (Inches)	Amps	Watts (In)	RPM	Vac (In.H2O)	Flow (CFM)	Air Watts
2.000	5.5	1265	28740	5.4	120.5	76
1.750	5.5	1260	28740	8.7	116.5	119
1.500	5.5	1259	28730	14.4	109.0	185
1.250	5.4	1253	28740	25.1	100.0	295
1.125	5.4	1251	29130	33.2	92.9	363
1.000	5.3	1214	29130	42.7	82.9	416
0.875	5.1	1191	29920	54.6	71.8	461
0.750	4.9	1131	30310	66.5	58.0	454
0.625	4.5	1049	31090	77.8	43.5	398
0.500	4.1	962	32660	88.2	29.6	307
0.375	3.7	865	34240	97.7	17.5	201
0.250	3.4	792	36210	105.9	8.4	105
0.000	3.0	709	37400	111.7	0.0	0

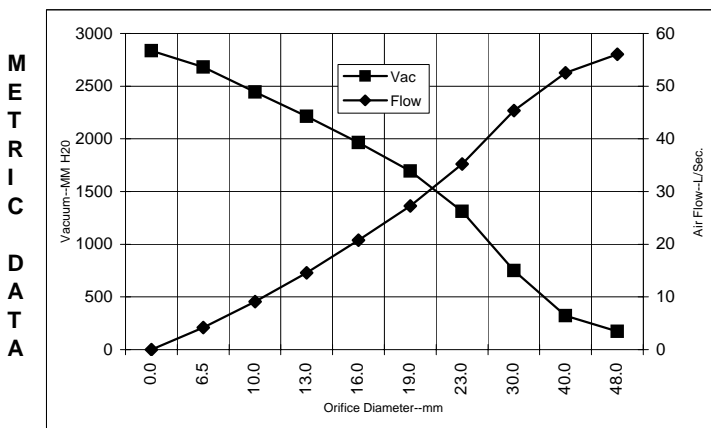

Orifice (mm)	Amps	Watts (In)	RPM	Vac (mm H2O)	Flow (L/Sec)	Air Watts
48.0	5.5	1263	28740	173	56.0	95
40.0	5.5	1259	28733	322	52.5	165
30.0	5.4	1252	28955	751	45.3	332
23.0	5.2	1197	29723	1311	35.2	450
19.0	4.9	1129	30326	1694	27.2	452
16.0	4.5	1052	31059	1964	20.8	400
13.0	4.2	971	32503	2215	14.6	316
10.0	3.8	880	34003	2446	9.1	217
6.5	3.4	796	36112	2680	4.2	110
0.0	3.0	709	37400	2836	0.0	0

Note: Metric Performance data is calculated from the ASTM data above.

* Data represents performance of a typical motor sampled from a large production quantity. Individual motor data may vary due to normal manufacturing variations.

Test Specs:	240 volts	Minimum Sealed Vacuum:	101.0	ORIFICE:	7/8 "	Minimum Vacuum:	50.0	Maximum Watts:	1290
-------------	-----------	------------------------	-------	----------	-------	-----------------	------	----------------	------



Ross Brown Sales Pty Ltd

ABN 28 000 690 362
Phone: 612 9899 2744 Fax: 612 9899 4233
Email: sales@rossbrownsales.com.au
Web: www.rossbrownsales.com.au



DIMENSIONS

NOTES:

1. MODEL NUMBER, DATE OF MANUFACTURE, PLANT LOCATION CODE, AGENCY RECOGNITION CODE, INSPECTOR'S CODE, MANUFACTURER'S NAME, "US PATENT: US 6,703,754 B1", VOLTAGE, FREQUENCY, AND "THERMALLY PROTECTED L 5 AMPS" TO APPEAR ON MOTOR.
2. MOUNTING MUST NOT RESTRICT THIS DIAMETER.
3. LEADS: 18GA STRANDED.
4. GROUNDING OR EARTHING PROVISIONS: USE HOLES AS INDICATED FOR GROUNDING OR EARTHING. REFER TO APPROPRIATE LISTING OR REGULATORY AGENCY FOR PROPER METHOD OF GROUNDING OR EARTHING.

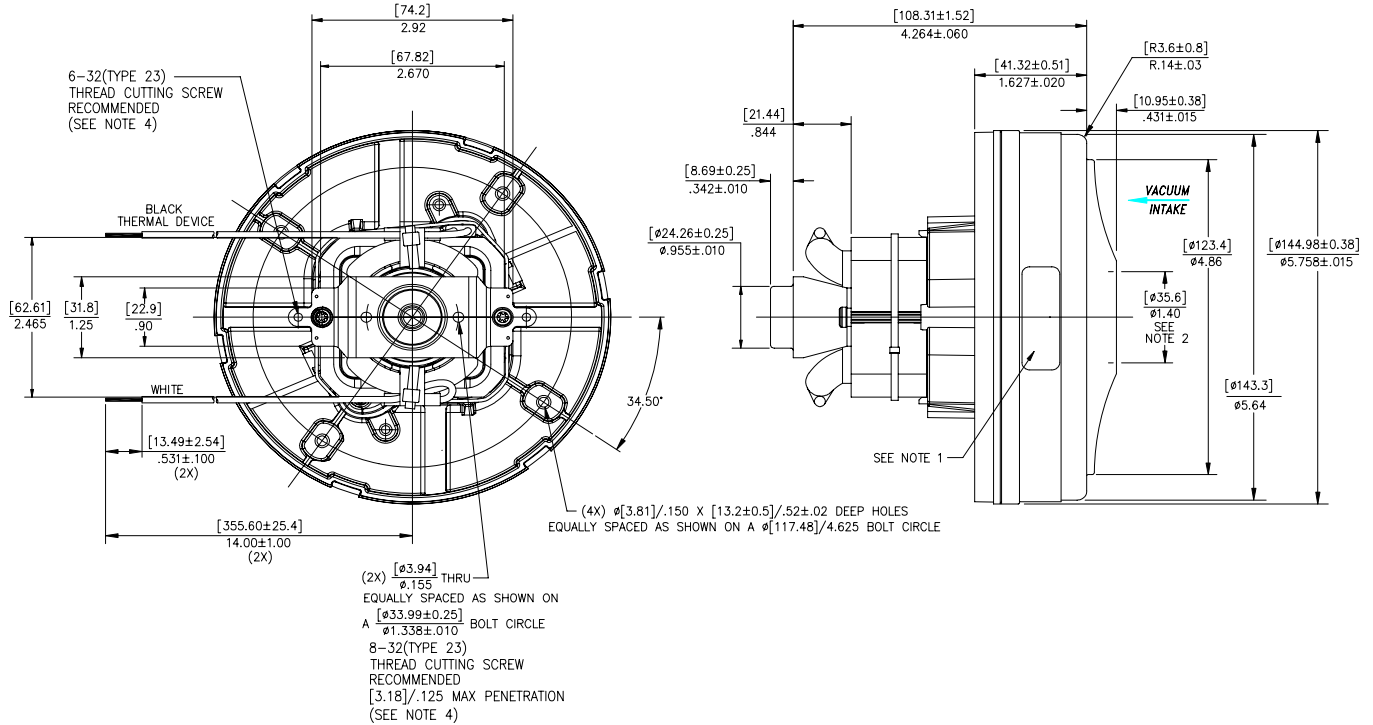

Advantek II - Plus

IMPORTANT NOTE: Pictorial and dimensional data are subject to change without notice. Contact factory for current revision levels.

WARNING - AMETEK Lamb Electric thru-flow vacuum motors must never be used in applications in which wet or moist conditions are involved, where dry chemicals or other volatile materials are present, or where airflow may be restricted or blocked. Such motors are designed to permit the vacuumed air to pass over the electrical winding to cool it. Thus any foam, liquid (including water), dry chemical, or other foreign substance coming in contact with electrical conductors could cause combustion (depending on volatility) or electrical shock. Failure to observe these precautions could result in property damage and severe personal injury, including death in extreme cases. All applications incorporating Lamb Electric motors should be submitted to Underwriters Laboratories Inc. or other appropriate organizations or agencies for testing specifically related to the safety of your equipment.

AMETEK/Lamb Electric Division
 627 Lake Street
 Kent, Ohio 44240
 U.S.A.
 Tel: (330) 673-3786 Fax: (330) 677-3812
www.lambelectric.com