



AMETEK LAMB ELECTRIC

Product Bulletin

Model: 119655-00

DESCRIPTION

- Two stage
- 240 volts
- 5.7"/145 mm diameter
- Double ball bearings
- Single speed
- Thru-flow discharge
- Aluminum fan end bracket
- Aluminum commutator bracket

DESIGN APPLICATION

- Equipment operating in environments not requiring separation of working air from motor ventilating air
- Designed to handle clean, dry, filtered air only.

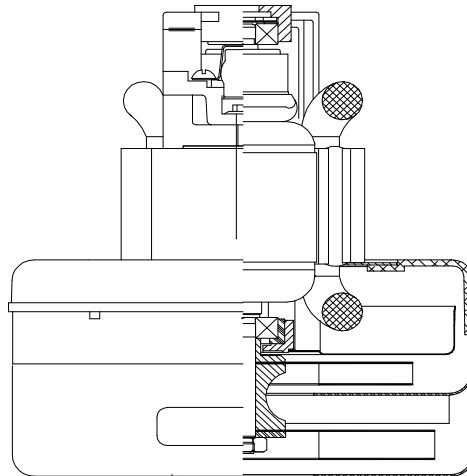

SPECIAL FEATURES

- Suitable for 240 volt AC operation, 50/60 Hz
- UL Recognized, category PGRY2 (E47185)
- Skeleton-frame design
- Provision for grounding
- The Lamb Electric vacuum motor line offers a wide range of performance levels to meet design needs

TYPICAL MOTOR PERFORMANCE.*

(At 240 volts, 60Hz, test data is corrected to standard conditions of 29.92 Hg, 68° F.)

ASTM DATA

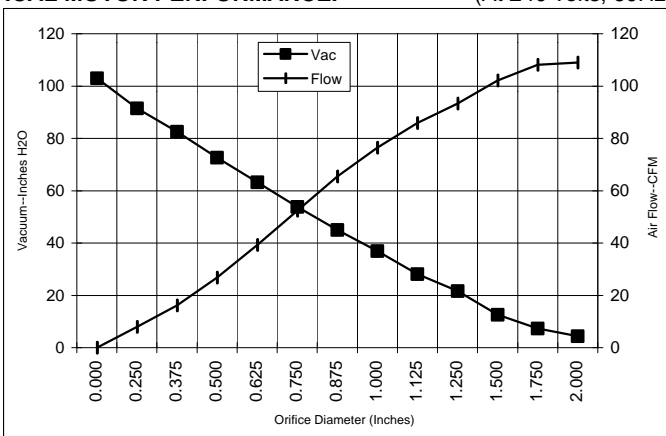

Orifice (Inches)	Amps	Watts (In)	RPM	Vac (In.H ₂ O)	Flow (CFM)	Air Watts
2.000	4.8	1139	21413	4.4	109.0	56
1.750	4.8	1141	21564	7.4	108.1	94
1.500	4.8	1142	21681	12.6	102.2	151
1.250	4.8	1141	21719	21.7	93.3	238
1.125	4.8	1135	21805	28.1	85.9	284
1.000	4.7	1121	21973	36.9	76.4	322
0.875	4.6	1102	22222	45.0	65.4	346
0.750	4.4	1063	22722	53.8	52.3	330
0.625	4.2	1000	23521	63.2	39.3	292
0.500	3.9	927	24606	72.6	26.8	229
0.375	3.6	855	26033	82.6	16.2	157
0.250	3.3	790	27368	91.5	7.9	85
0.000	3.0	731	29000	103.0	0.0	0

METRIC DATA

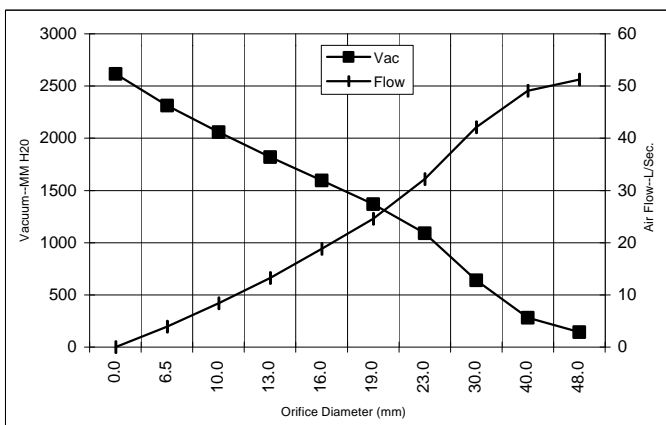

Orifice (mm)	Amps	Watts (In)	RPM	Vac (mm H ₂ O)	Flow (L/Sec)	Air Watts
48.0	4.8	1140	21479	145	51.3	73
40.0	4.8	1142	21646	280	49.1	134
30.0	4.8	1138	21766	641	42.1	263
23.0	4.6	1107	22160	1092	32.2	340
19.0	4.4	1062	22738	1371	24.6	329
16.0	4.2	1003	23489	1596	18.8	294
13.0	3.9	934	24498	1820	13.2	235
10.0	3.6	866	25819	2060	8.4	168
6.5	3.3	793	27301	2313	3.9	89
0.0	3.0	731	29000	2616	0.0	0

Note: Metric performance data is calculated from the ASTM data above.

* Data represents performance of a typical motor sampled from a large production quantity. Individual motor data may vary due to normal manufacturing variations.

Test Specs:	240 volts	Minimum Sealed Vacuum:	90.0"	ORIFICE:	13mm	Minimum Vacuum:	68.0"	Maximum Watts:	960
-------------	-----------	------------------------	-------	----------	------	-----------------	-------	----------------	-----

DIMENSIONS

NOTES:

- LEADS: 18GA STRANDED. LEADS CAN BE ANY COLOR EXCEPT GREEN OR GREEN WITH YELLOW STRIPE.
- GROUNDING OR EARTHING PROVISIONS: USE HOLES AS INDICATED FOR GROUNDING OR EARTHING.
REFER TO APPROPRIATE LISTING OR REGULATORY AGENCY FOR PROPER METHOD OF GROUNDING OR EARTHING.
- MOTOR IDENTIFICATION: MANUFACTURER'S NAME, MODEL NUMBER, VOLTAGE, FREQUENCY, INSPECTOR'S CODE, DATE OF MANUFACTURE, AGENCY RECOGNITION CODE; PLANT LOCATION CODE AND COUNTRY OF ORIGIN
- MOUNTING MUST NOT RESTRICT THIS DIAMETER.

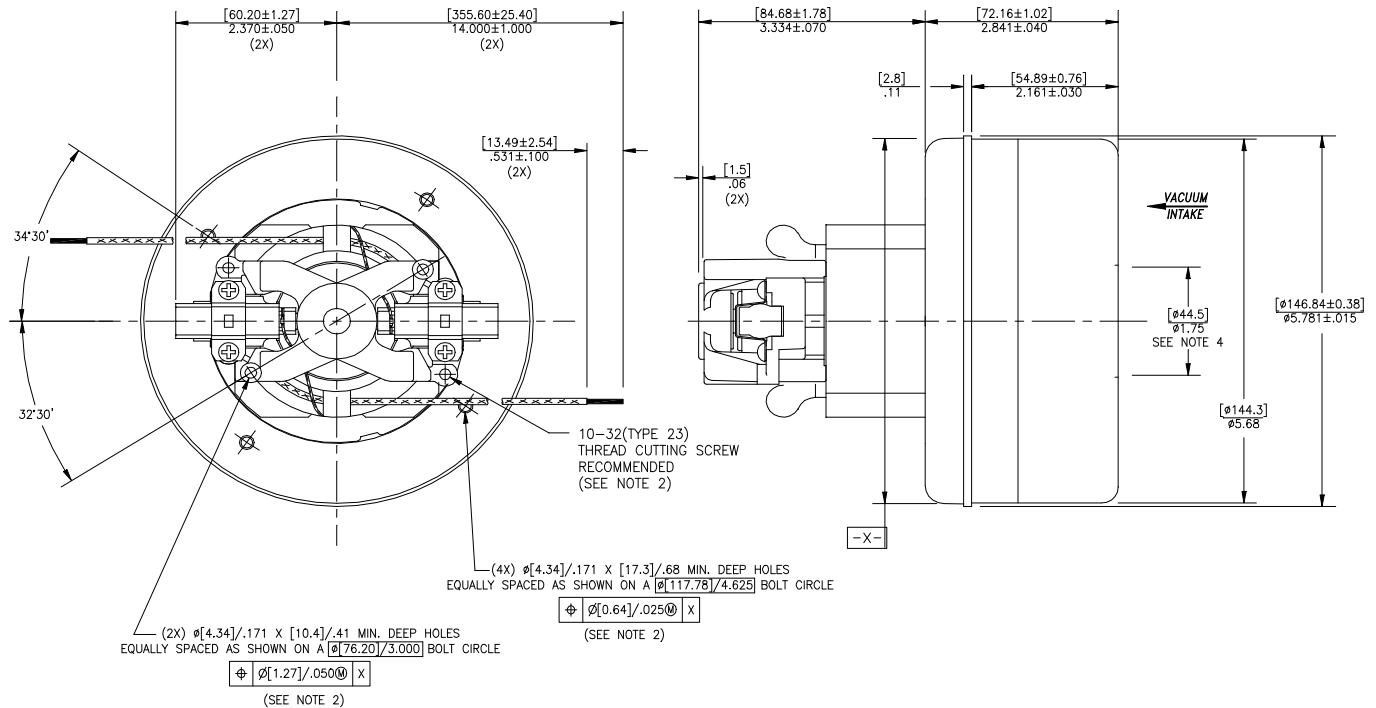

IMPORTANT NOTE: Pictorial and dimensional data are subject to change without notice. Contact factory for current revision levels.

WARNING - AMETEK Lamb Electric thru-flow vacuum motors must never be used in applications in which wet or moist conditions are involved, where dry chemicals or other volatile materials are present, or where airflow may be restricted or blocked. Such motors are designed to permit the vacuumed air to pass over the electrical winding to cool it. Thus any foam, liquid (including water), dry chemical, or other foreign substance coming in contact with electrical conductors could cause combustion (depending on volatility) or electrical shock. Failure to observe these precautions could result in property damage and severe personal injury, including death in extreme cases. All applications incorporating Lamb Electric motors should be submitted to Underwriters Laboratories Inc. or other appropriate organizations or agencies for testing specifically related to the safety of your equipment.

Issued: May, 2002



Ross Brown Sales Pty Ltd

ABN 28 000 690 362
 Phone: 612 9899 2744 Fax: 612 9899 4233
 Email: sales@rossbrownsales.com.au
 Web: www.rossbrownsales.com.au