



AMETEK

LAMB ELECTRIC

Product Bulletin

**Model: 117304-50
117304-61**

DESCRIPTION

- Two stage
- 230 volts
- 4.8"/122 mm diameter
- Ball/sleeve bearing construction
- Single speed
- Peripheral bypass discharge
- Aluminum fan end bracket
- Aluminum commutator bracket

DESIGN APPLICATION

- Equipment operating in environments requiring separation of working air from motor ventilating air
- Designed to handle clean, dry, filtered air only

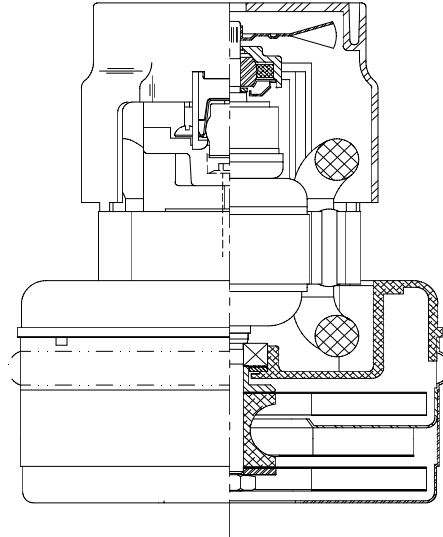

SPECIAL FEATURES

- Suitable for 230 volt operation, 50/60 Hz
- UL recognized, category PRGY2 (E47185)
- Provision for grounding
- Skeleton frame design
- The Lamb vacuum motor line offers a wide range of performance levels to meet design needs

Note:

Model 117304-61 is the same as 117304-50 except that it has interrupter brushes installed

TYPICAL MOTOR PERFORMANCE.*

(At 230 volts, 60Hz, test data is corrected to standard conditions of 29.92 Hg, 68° F.)

ASTM DATA

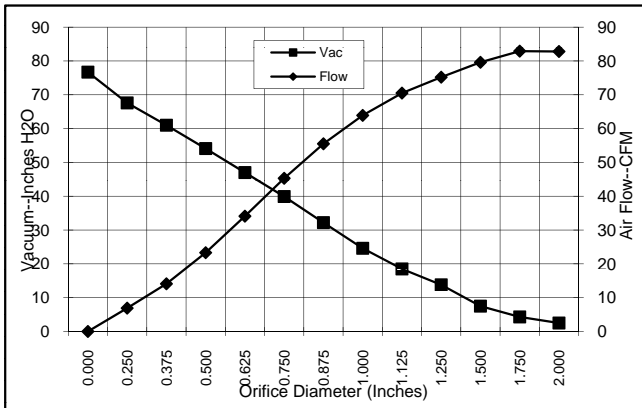

Orifice (Inches)	Amps	Watts (In)	RPM	Vac (In.H ₂ O)	Flow (CFM)	Air Watts
2.000	3.6	793	19544	2.5	82.8	24
1.750	3.6	795	19488	4.3	82.9	42
1.500	3.6	798	19432	7.5	79.6	70
1.250	3.7	800	19375	13.8	75.2	122
1.125	3.7	799	19402	18.5	70.5	154
1.000	3.6	794	19498	24.6	63.9	185
0.875	3.6	784	19676	32.2	55.5	210
0.750	3.5	759	20113	39.9	45.3	213
0.625	3.3	720	20899	47.0	34.1	188
0.500	3.1	672	21909	54.1	23.3	148
0.375	2.8	623	23061	61.0	14.1	101
0.250	2.6	580	24174	67.6	6.9	55
0.000	2.4	544	25190	76.7	0.0	0

METRIC DATA

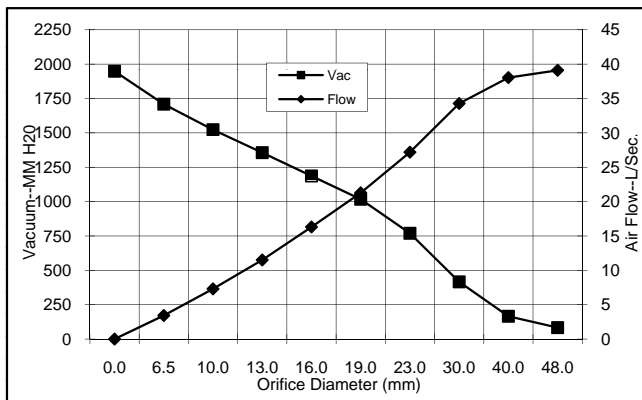

Orifice (mm)	Amps	Watts (In)	RPM	Vac (mm H ₂ O)	Flow (L/Sec)	Air Watts
48.0	3.6	794	19519	84	39.1	32
40.0	3.6	797	19449	166	38.0	62
30.0	3.7	799	19390	416	34.3	140
23.0	3.6	787	19632	770	27.2	204
19.0	3.5	758	20129	1017	21.3	213
16.0	3.3	722	20868	1187	16.3	189
13.0	3.1	677	21808	1356	11.5	152
10.0	2.8	630	22888	1523	7.3	108
6.5	2.6	582	24118	1709	3.4	57
0.0	2.4	544	25190	1948	0.0	0

Note: Metric performance data is calculated from the ASTM data above.

* Data represents performance of a typical motor sampled from a large production quantity. Individual motor data may vary to normal manufacturing variations.

Test Specs:	230 volts	Minimum Sealed Vacuum:	65.0"	ORIFICE:	7/8"	Minimum Vacuum:	30.0"	Maximum Watts:	870
--------------------	-----------	-------------------------------	-------	-----------------	------	------------------------	-------	-----------------------	-----

DIMENSIONS

NOTES:

1. LEADS: 18GA STRANDED, LEADS CAN BE ANY COLOR EXCEPT GREEN OR GREEN WITH YELLOW STRIPE.
2. GROUNDING OR EARTHING PROVISIONS: USE HOLES AS INDICATED FOR GROUNDING OR EARTHING. REFER TO APPROPRIATE LISTING OR REGULATORY AGENCY FOR PROPER METHOD OF GROUNDING OR EARTHING.

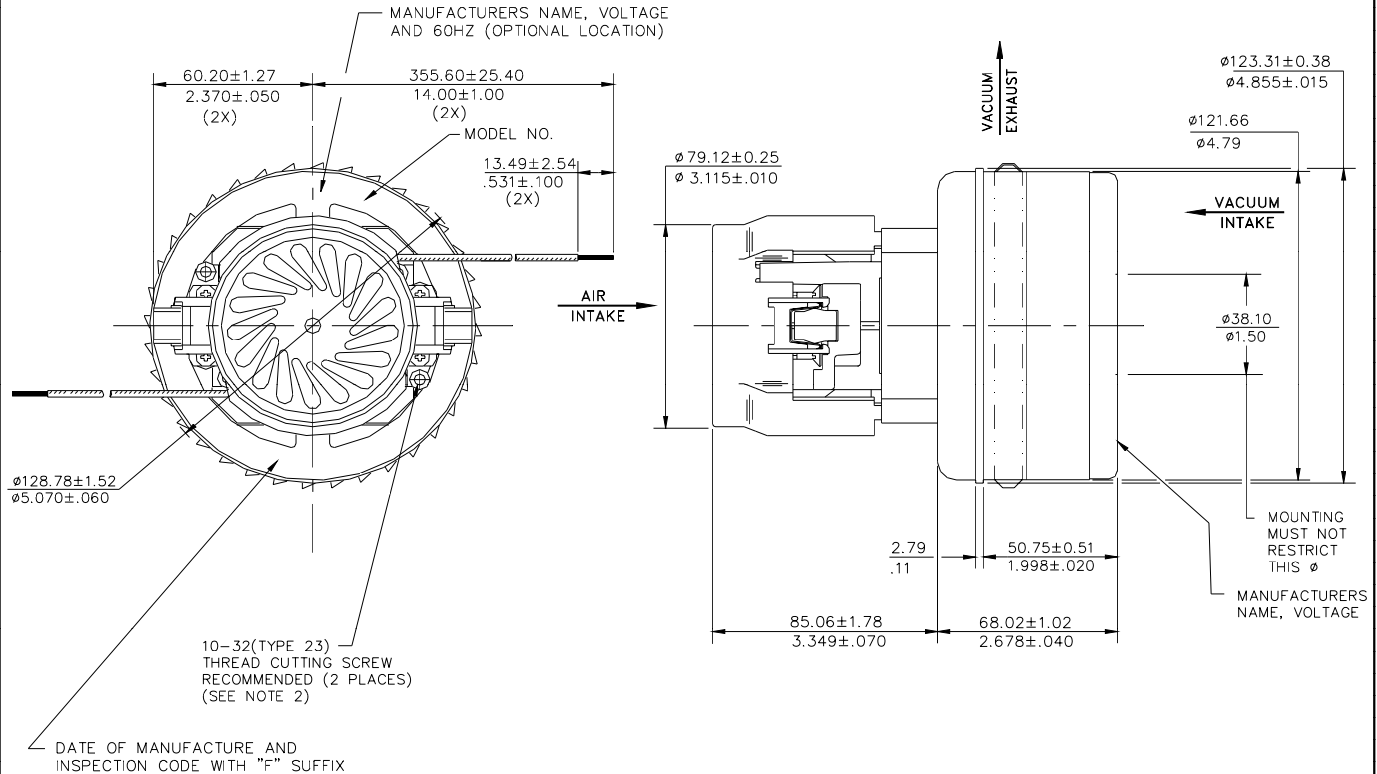

IMPORTANT NOTE: Pictorial and dimensional data are subject to change without notice. Contact factory for current revision levels.

WARNING - When using AMETEK/Lamb Electric bypass motors in machines that come in contact with foam, liquid (including water) or other foreign substances, the machine must be designed and constructed to prevent those substances from reaching the fan system, motor housing and electrical components. Lamb vacuum motors other than hazardous duty models should not be applied in machines that come in contact with dry chemicals or other volatile materials. Failure to observe these precautions could cause flashing (depending on volatility) or electrical shock which could result in property damage and severe bodily injury, including death in extreme cases. All applications incorporating Lamb motors should be submitted to appropriate organizations or agencies for testing specifically related to the safety of your equipment.



Ross Brown Sales Pty Ltd

ABN 28 000 690 362
 Phone: 612 9899 2744 Fax: 612 9899 4233
 Email: sales@rossbrownsales.com.au
 Web: www.rossbrownsales.com.au

Revised: January, 2004