



**Model: 117246-00**

**DESCRIPTION**

- Four stage
- 230 volts
- 5.7"/145 mm diameter
- Double ball bearings
- Single speed
- Tangential bypass discharge
- Aluminum fan end bracket
- Aluminum commutator bracket

**DESIGN APPLICATION**

- Equipment operating in environments requiring separation of working air from motor ventilating air
- Designed to handle clean, dry, filtered air only

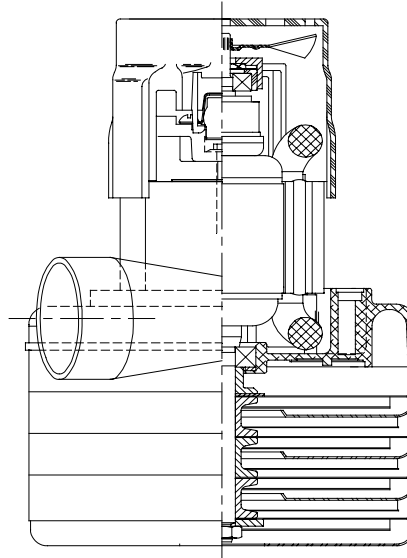

**SPECIAL FEATURES**

- Suitable for 230 volt AC operation, 50/60 Hz
- UL recognized, category PRGY2 (E47185)
- Provision for grounding
- 10 mm shaft and bearing system
- Special fans designed for high pressure/low volume operation
- The Lamb Electric vacuum motor line offers a wide range of performance levels to meet design needs

**TYPICAL MOTOR PERFORMANCE.\***

(At 230 volts, 60Hz, test data is corrected to standard conditions of 29.92 Hg, 68° F.)

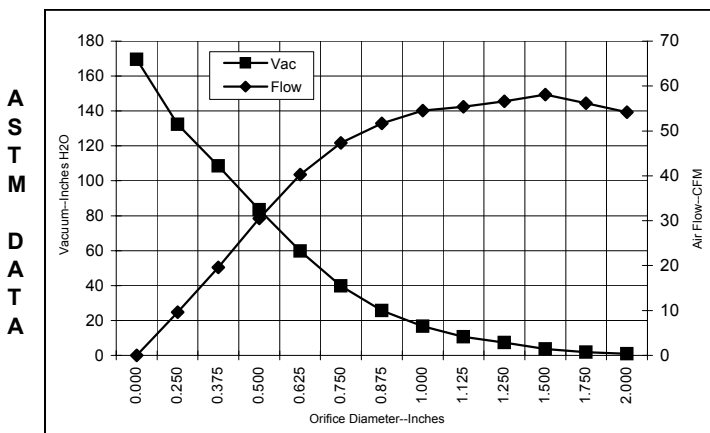

Orifice (Inches)	Amps	Watts (In)	RPM	Vac (In.H2O)	Flow (CFM)	Air Watts
2.000	6.7	1430	18930	1.0	54.2	7
1.750	6.6	1429	18925	1.9	56.2	13
1.500	6.6	1428	18926	3.7	58.1	26
1.250	6.6	1424	18925	7.3	56.6	49
1.125	6.6	1423	18928	10.7	55.4	70
1.000	6.6	1425	18938	16.6	54.5	106
0.875	6.6	1421	18956	25.6	51.7	156
0.750	6.6	1412	19002	39.7	47.3	221
0.625	6.4	1384	19197	59.7	40.3	283
0.500	6.1	1319	19698	83.4	30.5	299
0.375	5.5	1203	20670	108.6	19.6	250
0.250	4.8	1059	22056	132.4	9.6	149
0.000	4.0	896	23928	169.5	0.0	0

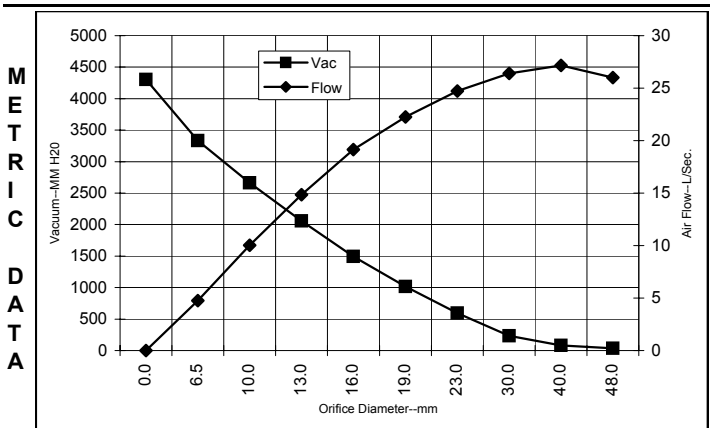

Orifice (mm)	Amps	Watts (In)	RPM	Vac (mm H2O)	Flow (L/Sec)	Air Watts
48.0	6.7	1430	18928	35	26.0	10
40.0	6.6	1428	18926	80	27.2	22
30.0	6.6	1423	18927	233	26.4	61
23.0	6.6	1422	18952	593	24.7	144
19.0	6.6	1411	19006	1019	22.3	222
16.0	6.4	1385	19189	1496	19.2	281
13.0	6.1	1326	19648	2058	14.9	297
10.0	5.6	1220	20524	2662	10.0	257
6.5	4.8	1066	21987	3333	4.8	154
0.0	4.0	896	23928	4305	0.0	0

Note: Metric performance data is calculated from the ASTM data above.

\* Data represents performance of a typical motor sampled from a large production quantity. Individual motor data may vary due to normal manufacturing variations.

<b>Test Specs:</b>	230 volts	<b>Minimum Sealed Vacuum:</b>	160.0"	<b>ORIFICE:</b>	13mm	<b>Minimum Vacuum:</b>	78.0"	<b>Maximum Watts:</b>	1490
--------------------	-----------	-------------------------------	--------	-----------------	------	------------------------	-------	-----------------------	------

