



Model: 116604-00

DESCRIPTION

- Two stage
- 240 volts
- 5.7"/145 mm diameter
- Double ball bearings
- Single speed
- Thru-flow discharge
- Aluminum fan bracket
- Aluminum commutator bracket

DESIGN APPLICATION

- Equipment operating in environments not requiring separation of working air from motor ventilating air
- Designed to handle clean, dry, filtered air only

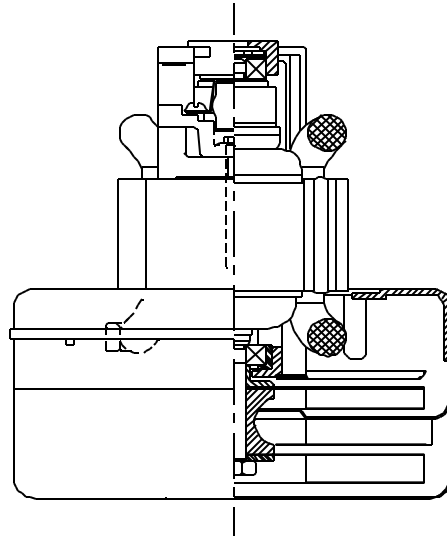

SPECIAL FEATURES

- Suitable for 240 volt AC operation, 50/60 Hz
- UL Recognized, category PRGY2 (E47185)
- Thermal protection, automatic reset, UL category XEWR2 (E27701)
- Provision for grounding
- Skeleton-frame design
- The Lamb Electric vacuum motor line offers a wide range of performance levels to meet design needs

TYPICAL MOTOR PERFORMANCE.*

(At 240 volts, 60Hz, test data is corrected to standard conditions of 29.92 Hg, 68° F.)

ASTM DATA

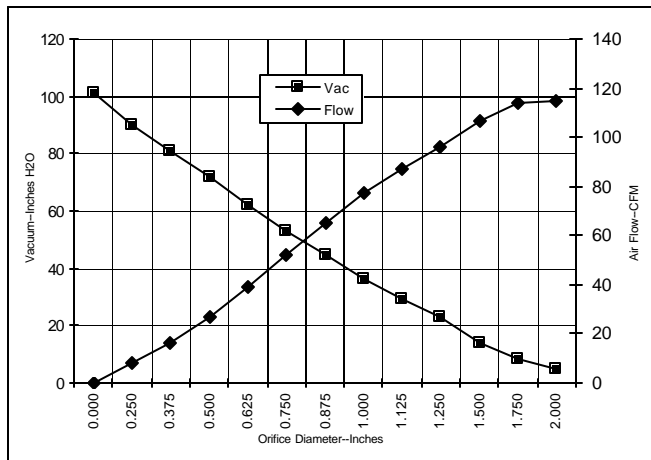

Orifice (Inches)	Amps	Watts (In)	RPM	Vac (In.H ₂ O)	Flow (CFM)	Air Watts
2.000	5.2	1179	19335	4.9	114.8	66
1.750	5.2	1189	19395	8.3	114.2	111
1.500	5.3	1199	19255	13.8	107.0	174
1.250	5.3	1219	19015	23.2	96.4	263
1.125	5.3	1207	19145	29.2	87.4	300
1.000	5.2	1183	19350	36.6	77.1	332
0.875	5.0	1130	19595	44.8	65.2	343
0.750	4.8	1077	20175	53.3	52.1	327
0.625	4.4	1020	20895	62.4	39.0	286
0.500	4.1	944	21870	71.9	26.7	225
0.375	3.7	860	23105	81.0	16.0	152
0.250	3.4	785	24310	90.2	7.8	83
0.000	3.1	726	25410	101.5	0.0	0

METRIC DATA

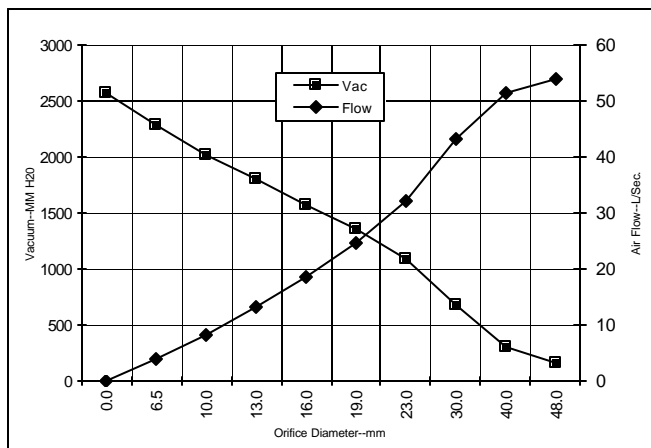

Orifice (mm)	Amps	Watts (In)	RPM	Vac (mm H ₂ O)	Flow (L/Sec)	Air Watts
48.0	5.2	1183	19361	162	54.1	86
40.0	5.3	1196	19297	309	51.5	155
30.0	5.3	1212	19087	673	43.2	283
23.0	5.1	1143	19534	1086	32.2	340
19.0	4.8	1076	20189	1358	24.5	326
16.0	4.5	1022	20866	1576	18.7	288
13.0	4.1	952	21773	1802	13.2	231
10.0	3.8	873	22920	2023	8.3	163
6.5	3.4	789	24250	2279	3.9	86
0.0	3.1	726	25410	2578	0.0	0

Note: Metric performance data is calculated from the ASTM data above.

* Data represents performance of a typical motor sampled from a large production quantity. Individual motor data may vary due to normal manufacturing tolerances.

Test Specs: 240 volts	Minimum Sealed Vacuum: 92.0"	ORIFICE: 7/8 "	Minimum Vacuum: 39.0"	Maximum Watts: 1225
------------------------------	-------------------------------------	-----------------------	------------------------------	----------------------------

