



DESCRIPTION

- One stage
- 240 volts
- 5.7"/145 mm diameter
- Ball/sleeve bearings
- Single speed
- Peripheral bypass discharge
- Thermoset fan end bracket
- Aluminum commutator bracket

DESIGN APPLICATION

- Equipment operating in environments requiring separation of working air from motor ventilating air
- Designed to handle clean, dry, filtered air only

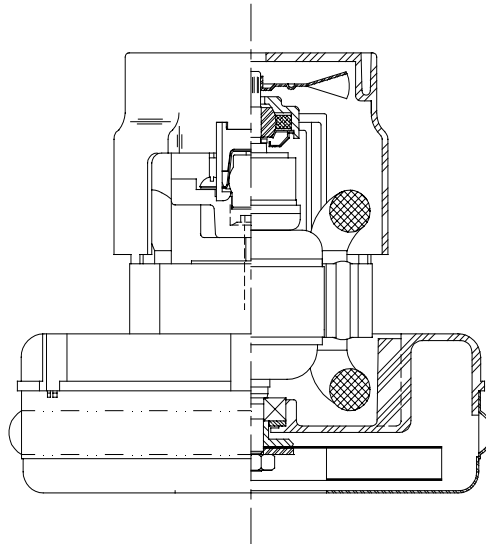

SPECIAL FEATURES

- Suitable for 240 volt AC operation, 50/60 Hz
- UL Recognized, category PRGY2 (E47185)
- Provision for grounding
- Skeleton frame design
- High air flow fan system
- The Lamb vacuum motor line offers a wide range of performance levels to meet design needs

TYPICAL MOTOR PERFORMANCE.*

(At 240 volts, 60Hz, test data is corrected to standard conditions of 29.92 Hg, 68° F.)

ASTM DATA

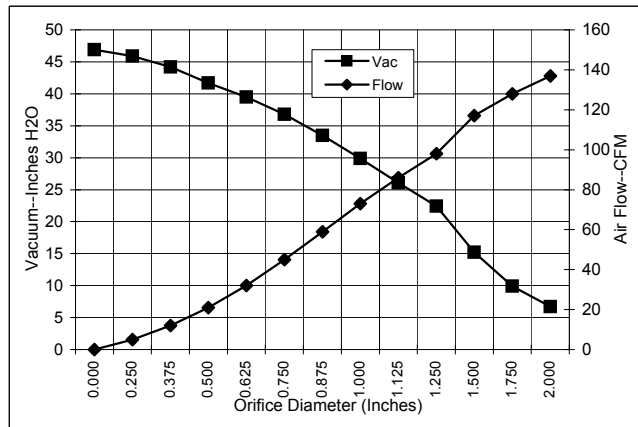

Orifice (Inches)	Amps	Watts (In)	RPM	Vac (In.H ₂ O)	Flow (CFM)	Air Watts
2.000	3.8	860	19981	6.7	137.0	108
1.750	3.8	853	20166	9.9	128.0	149
1.500	3.7	845	20357	15.2	117.0	209
1.250	3.7	837	20546	22.4	98.0	259
1.125	3.6	824	20760	26.1	86.0	264
1.000	3.5	800	21128	29.9	73.0	255
0.875	3.4	774	21533	33.5	59.0	232
0.750	3.3	741	22100	36.8	45.0	196
0.625	3.1	715	22620	39.5	32.0	151
0.500	3.0	681	23160	41.7	21.0	105
0.375	2.8	652	23765	44.2	12.0	64
0.250	2.8	634	24202	45.9	5.0	30
0.000	2.7	618	24200	46.9	0.0	0

METRIC DATA

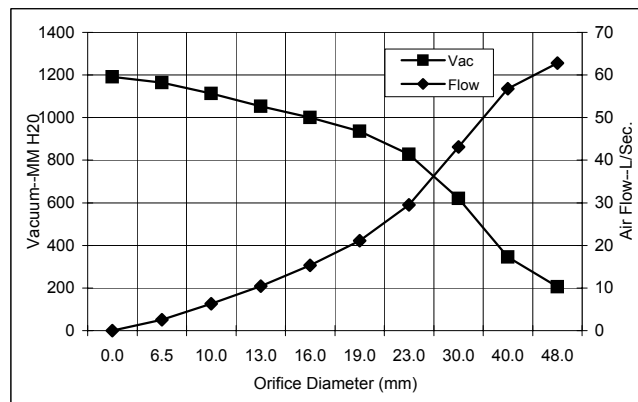

Orifice (mm)	Amps	Watts (In)	RPM	Vac (mm H ₂ O)	Flow (L/Sec)	Air Watts
48.0	3.8	857	20062	206	62.8	126
40.0	3.7	847	20300	346	56.8	191
30.0	3.6	830	20664	621	43.1	262
23.0	3.4	781	21432	828	29.5	238
19.0	3.3	740	22110	936	21.1	195
16.0	3.1	716	22599	1001	15.3	153
13.0	3.0	684	23106	1054	10.4	110
10.0	2.8	656	23674	1113	6.3	70
6.5	2.8	635	24180	1164	2.5	32
0.0	2.7	618	24200	1191	0.0	0

Note: Metric performance data is calculated from the ASTM data above.

* Data represents performance of a typical motor sampled from a large production quantity. Individual motor data may vary to normal manufacturing variations.

Test Specs:	240 volts	Minimum Sealed Vacuum:	40.0"	ORIFICE:	7/8"	Minimum Vacuum:	29.0"	Maximum Watts:	730
--------------------	-----------	-------------------------------	-------	-----------------	------	------------------------	-------	-----------------------	-----

DIMENSIONS

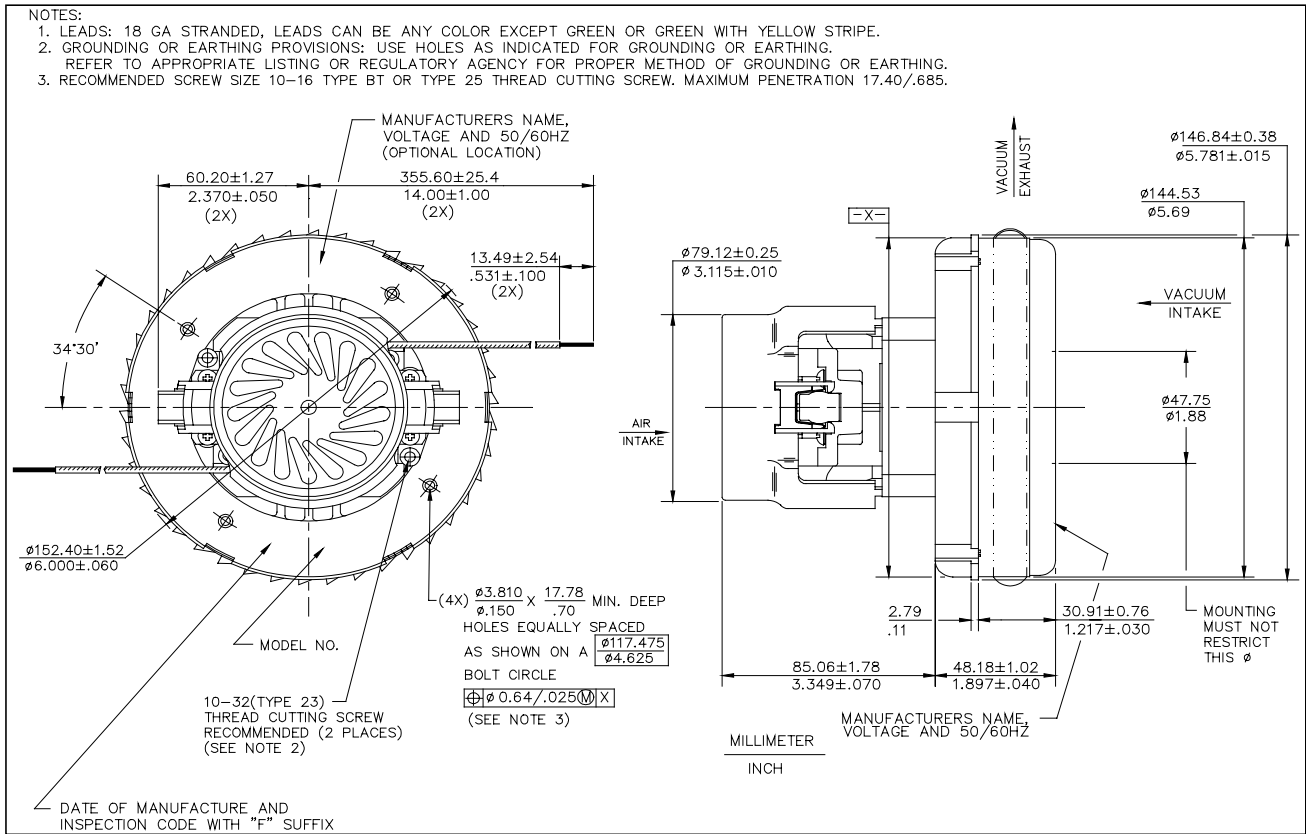

IMPORTANT NOTE: Pictorial and dimensional data are subject to change without notice. Contact factory for current revision levels.

WARNING - When using AMETEK/Lamb Electric bypass motors in machines that come in contact with foam, liquid (including water) or other foreign substances, the machine must be designed and constructed to prevent those substances from reaching the fan system, motor housing and electrical components. Lamb vacuum motors other than hazardous duty models should not be applied in machines that come in contact with dry chemicals or other volatile materials. Failure to observe these precautions could cause flashing (depending on volatility) or electrical shock which could result in property damage and severe bodily injury, including death in extreme cases. All applications incorporating Lamb motors should be submitted to appropriate organizations or agencies for testing specifically related to the safety of your equipment.



Ross Brown Sales Pty Ltd

ABN 28 000 690 362
 Phone: 612 9899 2744 Fax: 612 9899 4233
 Email: sales@rossbrownsales.com.au
 Web: www.rossbrownsales.com.au