



DESCRIPTION

- Two stage
- 240 volts
- 7.2"/183 mm diameter
- Double ball bearings
- Single speed
- Peripheral bypass discharge
- Aluminum fan bracket
- Aluminum commutator bracket

DESIGN APPLICATION

- Equipment operating in environments requiring separation of working air from motor ventilating air
- Designed to handle clean, dry, filtered air only

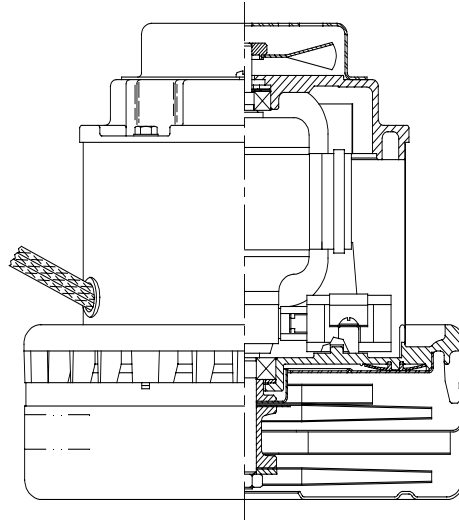

SPECIAL FEATURES

- Suitable for 240 volt AC operation, 50/60 Hz
- UL recognized, category PRGY2 (E47185)
- Provision for grounding
- Epoxy painted fan case
- Patented air seal bearing construction, U.S. Patent #4,088,424
- The Lamb Electric vacuum motor line offers a wide range of performance levels to meet design needs

TYPICAL MOTOR PERFORMANCE.*

(At 240 volts, 60Hz, test data is corrected to standard conditions of 29.92 Hg, 68° F.)

ASTM DATA

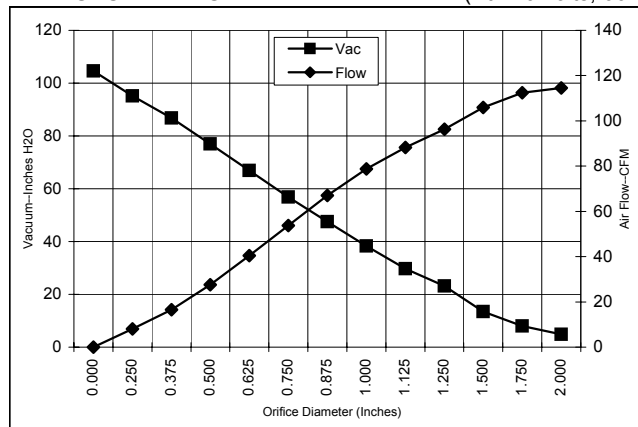

Orifice (Inches)	Amps	Watts (In)	RPM	Vac (In.H ₂ O)	Flow (CFM)	Air Watts
2.000	7.2	1511	16230	4.8	114.6	65
1.750	7.1	1499	16131	8.0	112.4	106
1.500	7.2	1501	16062	13.5	105.9	169
1.250	7.2	1508	15980	23.1	96.3	262
1.125	7.2	1512	15973	29.7	88.2	308
1.000	7.2	1507	16021	38.3	78.8	354
0.875	7.0	1482	16199	47.5	67.1	375
0.750	6.8	1430	16535	56.9	53.8	360
0.625	6.4	17081	17081	66.9	40.4	318
0.500	6.0	1269	17756	77.0	27.6	250
0.375	5.5	1175	18569	86.8	16.6	169
0.250	5.1	1088	19375	95.2	8.0	89
0.000	4.7	1019	20109	104.6	0.0	0

METRIC DATA

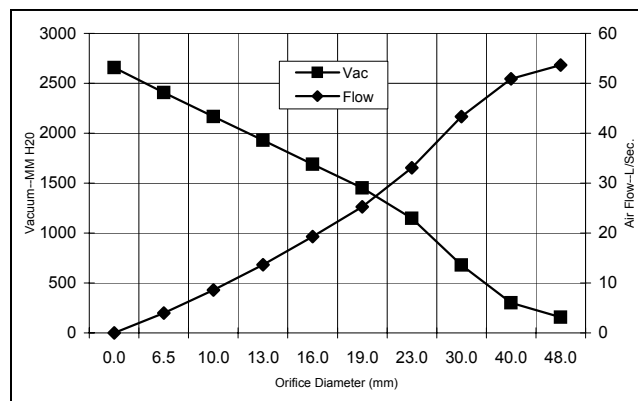

Orifice (mm)	Amps	Watts (In)	RPM	Vac (mm H ₂ O)	Flow (L/Sec)	Air Watts
48.0	7.2	1506	16186	158	53.6	83
40.0	7.2	1500	16083	301	50.9	150
30.0	7.2	1510	15976	679	43.4	287
23.0	7.1	1488	16155	1148	33.1	370
19.0	6.8	1743	16546	1450	25.3	359
16.0	6.4	16455	17059	1689	19.3	320
13.0	6.0	2850	17689	1930	13.6	257
10.0	5.6	1189	18447	2167	8.6	181
6.5	5.1	1092	19335	2407	4.0	93
0.0	4.7	1019	20109	2657	0.0	0

Note: Metric performance data is calculated from the ASTM data above.

* Data represents performance of a typical motor sampled from a large production quantity. Individual motor data may vary due to normal manufacturing variations.

Test Specs:	220 volts	Minimum Sealed Vacuum:	90.0"	ORIFICE:	7/8"	Minimum Vacuum:	39.0"	Maximum Watts:	1250
-------------	-----------	------------------------	-------	----------	------	-----------------	-------	----------------	------

DIMENSIONS

NOTES:

- LEADS: POWER: #16 GA., ONE BLACK, ONE WHITE.
GROUND: #18 GA., GREEN WITH YELLOW STRIPE.

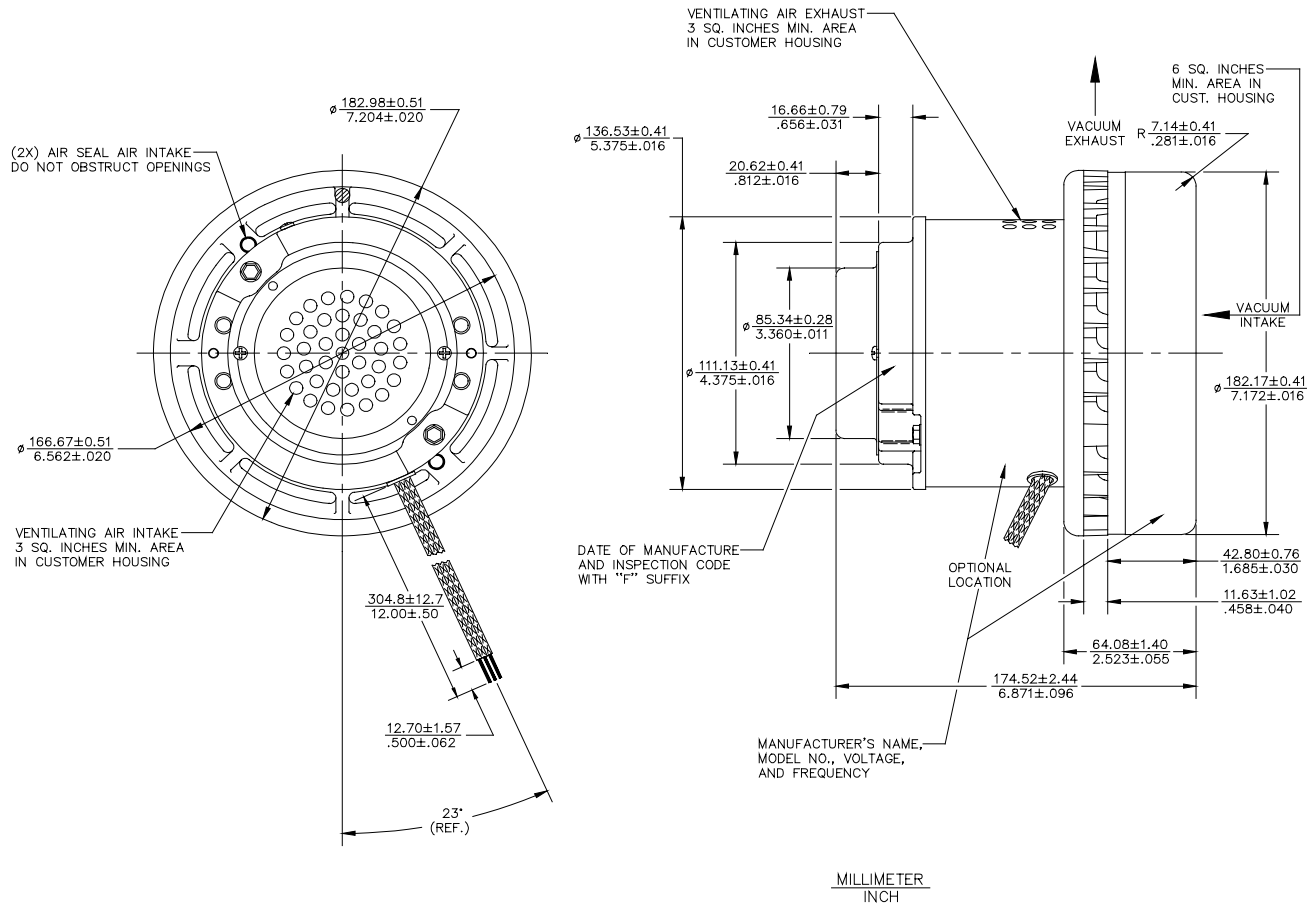

IMPORTANT NOTE: Pictorial and dimensional data are subject to change without notice. Contact factory for current revision levels.

WARNING - When using AMETEK Lamb Electric bypass motors in machines that come in contact with foam, liquid (including water), or other foreign substances, the machine must be designed and constructed to prevent those substances from reaching the fan system, motor housing, and electrical components. Lamb Electric vacuum motors other than hazardous duty models should not be applied in machines that come in contact with dry chemicals or other volatile materials. Failure to observe these precautions could cause flashing (depending on volatility) or electrical shock which could result in property damage and severe bodily injury, including death in extreme cases. All applications incorporating Lamb Electric motors should be submitted to appropriate organizations or agencies for testing specifically related to the safety of your equipment.



Ross Brown Sales Pty Ltd

ABN 28 000 690 362
Phone: 612 9899 2744 Fax: 612 9899 4233
Email: sales@rossbrownsales.com.au
Web: www.rossbrownsales.com.au

Issued: March, 1998