



**DESCRIPTION**

- Three stage
- 240 volts
- 7.5"/191 mm diameter
- Double ball bearings
- Single speed
- Peripheral bypass discharge
- Aluminum fan end bracket
- Aluminum commutator bracket

**DESIGN APPLICATION**

- Equipment operating in environments requiring separation of working air from motor ventilating air
- Designed to handle clean, dry, filtered air only

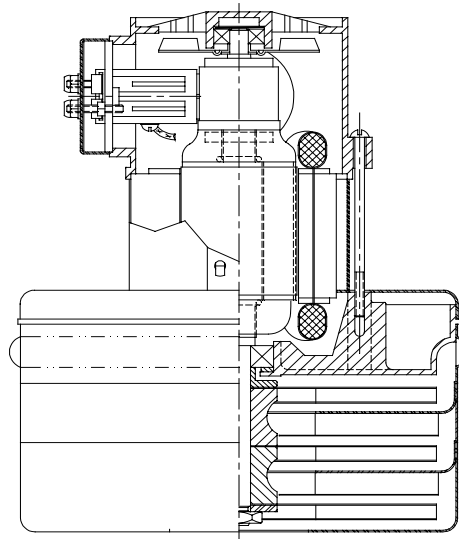

**SPECIAL FEATURES**

- Suitable for 240 volt AC operation, 50/60 Hz
- UL recognized, category PRGY2 (E47185)
- Provision for grounding
- High air flow fan system
- The Lamb Electric vacuum motor line offers a wide range of performance levels to meet design needs

**TYPICAL MOTOR PERFORMANCE.\***

(At 240 volts, 60Hz, test data is corrected to standard conditions of 29.92 Hg, 68° F.)

**ASTM DATA**

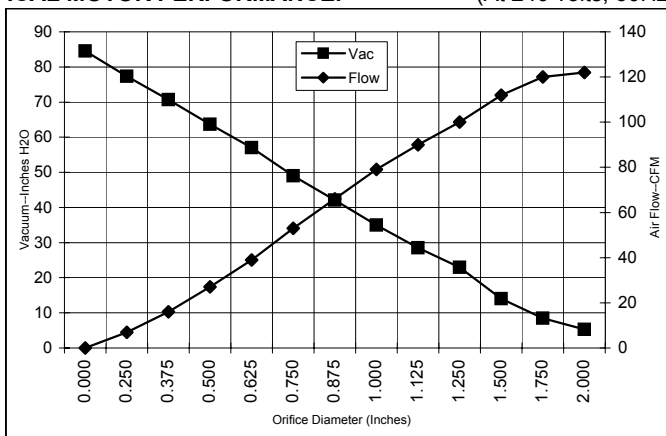

Orifice (Inches)	Amps	Watts (In)	RPM	Vac (In.H <sub>2</sub> O)	Flow (CFM)	Air Watts
2.000	5.0	998	11125	5.3	122.0	76
1.750	5.0	998	11000	8.5	120.0	120
1.500	5.1	1018	10950	14.0	112.0	185
1.250	5.2	1032	10800	23.0	100.0	270
1.125	5.2	1028	10800	28.5	90.0	303
1.000	5.1	1024	10875	35.0	79.0	354
0.875	5.0	998	11125	42.1	66.0	329
0.750	4.8	963	11450	49.0	53.0	303
0.625	4.5	910	11925	57.0	39.0	264
0.500	4.2	854	12500	63.7	27.0	200
0.375	3.8	799	13050	70.7	16.0	131
0.250	3.5	746	13700	77.3	7.0	67
0.000	3.2	701	14300	84.5	0.0	0

**METRIC DATA**

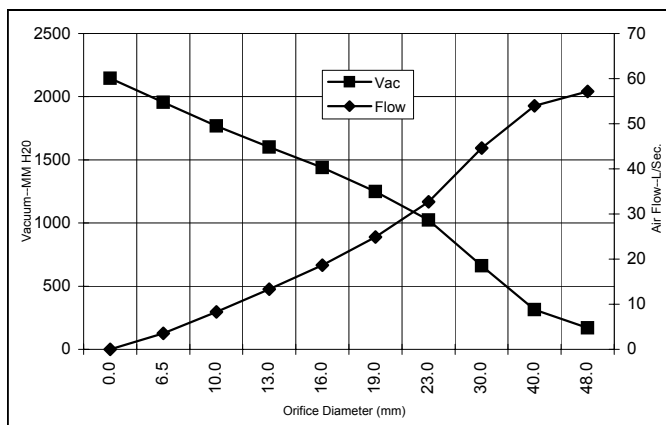

Orifice (mm)	Amps	Watts (In)	RPM	Vac (mm H <sub>2</sub> O)	Flow (L/Sec)	Air Watts
48.0	5.0	998	11070	170	57.2	95
40.0	5.1	1012	10965	314	54.0	166
30.0	5.2	1030	10800	661	44.6	288
23.0	5.0	1005	11063	1024	32.7	335
19.0	4.8	962	11460	1249	24.9	302
16.0	4.5	912	11906	1440	18.7	266
13.0	4.2	860	12443	1601	13.3	206
10.0	3.9	807	12968	1769	8.3	141
6.5	3.5	749	13668	1955	3.5	70
0.0	3.2	701	14300	2146	0.0	0

Note: Metric performance data is calculated from the ASTM data above.

\* Data represents performance of a typical motor sampled from a large production quantity. Individual motor data may vary due to normal manufacturing variations.

<b>Test Specs:</b>	<b>240 volts</b>	<b>Minimum Sealed Vacuum:</b>	<b>80.0"</b>	<b>ORIFICE:</b>	<b>7/8 "</b>	<b>Minimum Vacuum:</b>	<b>39.0"</b>	<b>Maximum Watts:</b>	<b>1250</b>
--------------------	------------------	-------------------------------	--------------	-----------------	--------------	------------------------	--------------	-----------------------	-------------

**DIMENSIONS**

NOTES:

1. GROUNDING OR EARTHING PROVISIONS: USE HOLES AS INDICATED FOR GROUNDING OR EARTHING. REFER TO APPROPRIATE LISTING OR REGULATORY AGENCY FOR PROPER METHOD OF GROUNDING OR EARTHING.

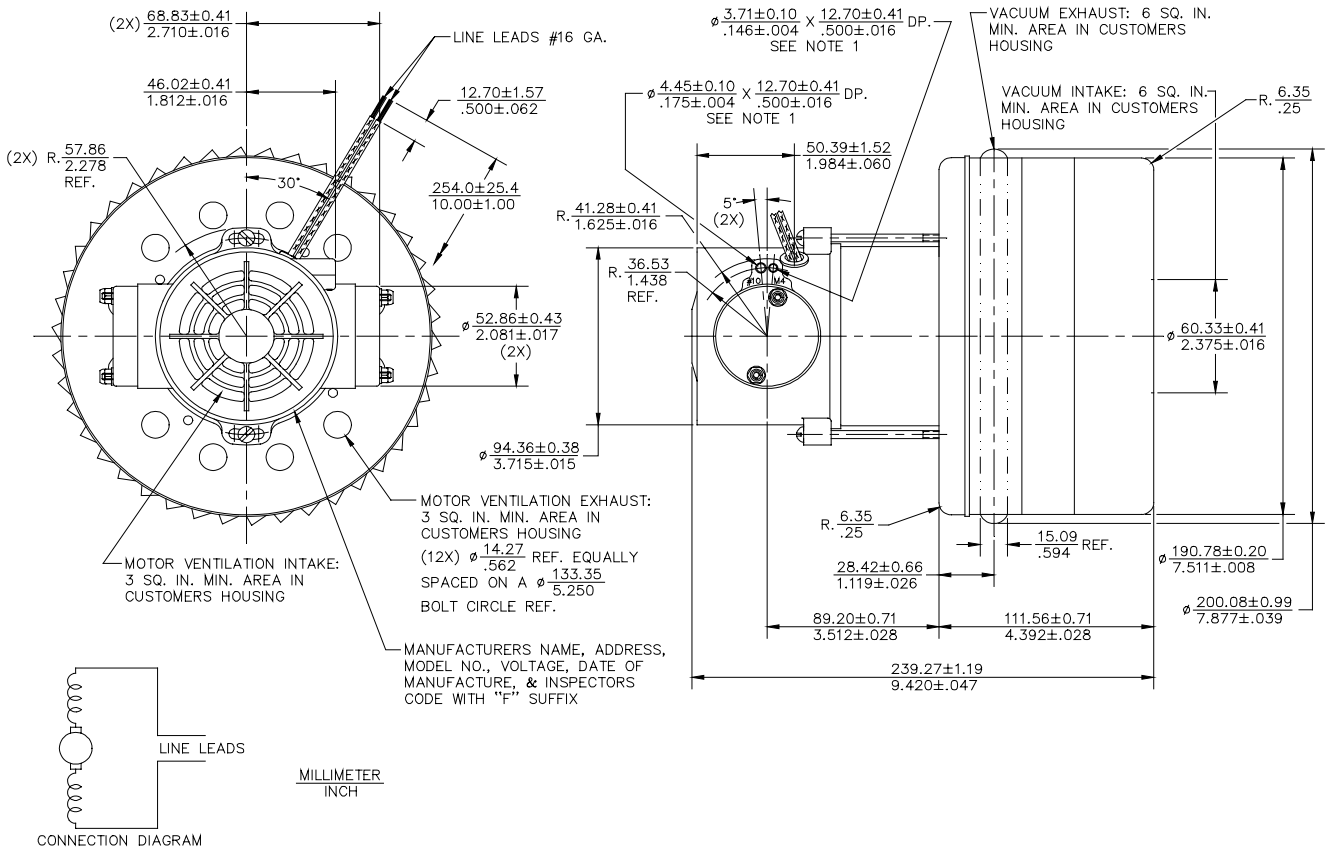

**IMPORTANT NOTE:** Pictorial and dimensional data are subject to change without notice. Contact factory for current revision levels.

**WARNING** - When using AMETEK Lamb Electric bypass motors in machines that come in contact with foam, liquid (including water), or other foreign substances, the machine must be designed and constructed to prevent those substances from reaching the fan system, motor housing, and electrical components. Lamb Electric vacuum motors other than hazardous duty models should not be applied in machines that come in contact with dry chemicals or other volatile materials. Failure to observe these precautions could cause flashing (depending on volatility) or electrical shock which could result in property damage and severe bodily injury, including death in extreme cases. All applications incorporating Lamb Electric motors should be submitted to appropriate organizations or agencies for testing specifically related to the safety of your equipment.



**Ross Brown Sales Pty Ltd**

ABN 28 000 690 362  
 Phone: 612 9899 2744 Fax: 612 9899 4233  
 Email: [sales@rossbrownsales.com.au](mailto:sales@rossbrownsales.com.au)  
 Web: [www.rossbrownsales.com.au](http://www.rossbrownsales.com.au)

Issued: March, 1998